



UZAVÍRACÍ KLAPKY
BUTTERFLY VALVES

OBSAH

CONTENTS

- 2 Uzavírací klapky | Butterfly Valves
- 3 Konstrukce | Components
- 4 Skladba katalogového čísla | Catalogue number
- 7 Průtoková charakteristika | Head Loss Diagram
- 8 Technické údaje | Technical Data
- 9 Uzavírací klapky typ FL(W)
Valves type FL(W)
- 14 Uzavírací klapky typ LUG(W)
Valves type LUG(W)
- 19 Uzavírací klapky typ FG(W)
Valves type FG(W)
- 24 Uzavírací klapky typ KL
Valves type KL
- 28 Uzavírací klapky typ VV
Valves type VV
- 31 Uzavírací klapky typ BBNV(W) / FFNV(W)
Valves type BBNV(W) / FFNV(W)

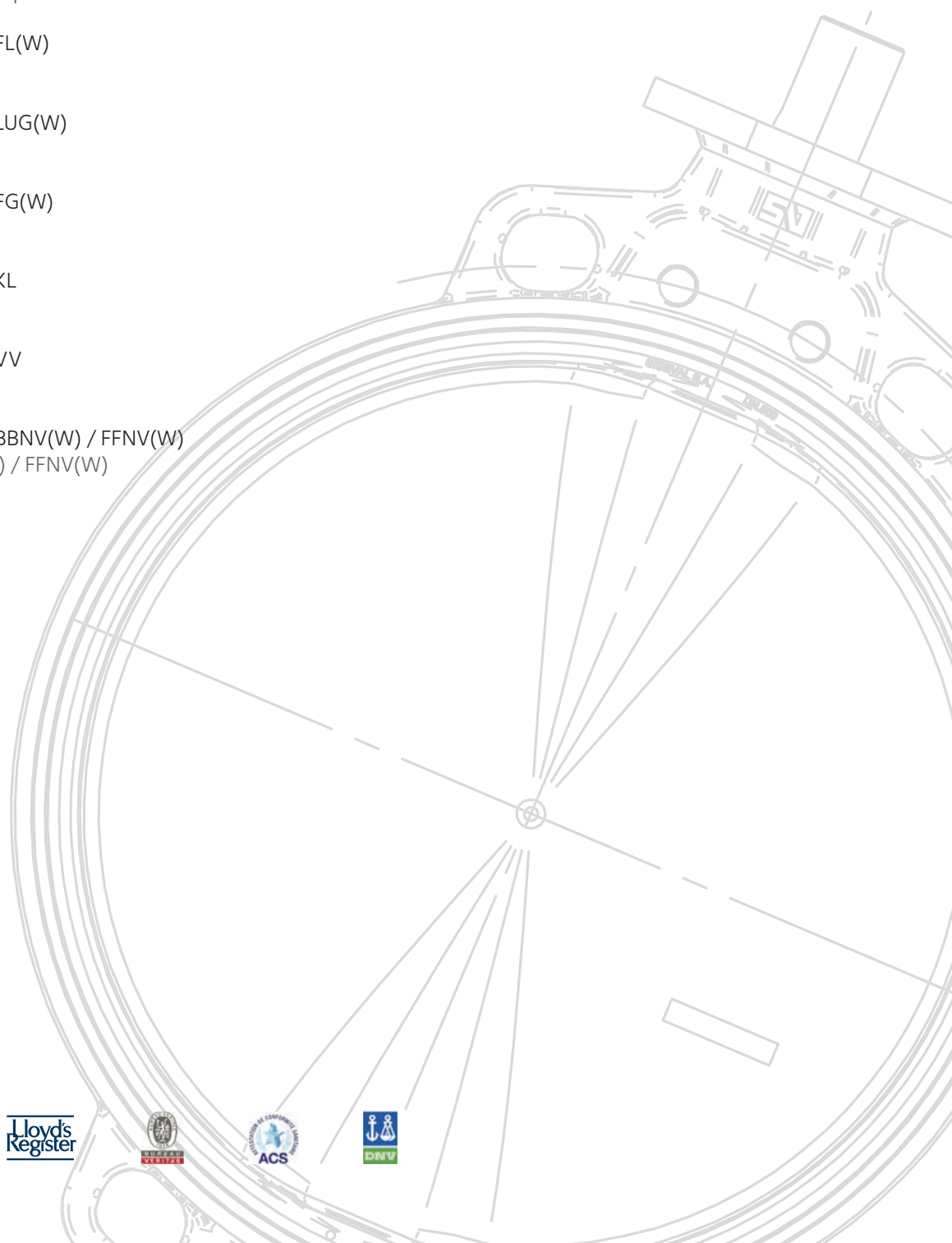

UZAVÍRACÍ KLAPKY

BUTTERFLY VALVES

Uzavírací klapky slouží k uzavření / otevření průtoku pracovní látky potrubím otočením disku o 90°. Měkká elastomerová manžeta zajišťuje 100% těsnost armatury v obou směrech.

V současnosti uzavírací klapky patří mezi nejobvyklejší součásti potrubních systémů v mnoha průmyslových oblastech, např. plynárenství, vodárenství, potravinářském průmyslu chemickém a petrochemickém průmyslu, energetice aj.

Vlastnosti a výhody použití:

- obousměrná trvalá těsnost
- nízká tlaková ztráta
- krátká stavební délka
- nízká hmotnost
- nízký ovládací moment
- široká nabídka materiálových variant těles, disků manžet
- kompletně rozebíratelná konstrukce
- zaměnitelnost náhradních dílů mezi všemi typy klapek v sortimentu
- různé možnosti ovládání
- snadná montáž a údržba
- provozní spolehlivost a dlouhodobá životnost

Butterfly valves are used to closing/opening the flow of working fluid in piping by means of disc rotating by 90°. The elastomer liner provides 100% tightness in both directions.

Now butterfly valves are the most common components in pipeline systems in many industrial areas, for instance in gas industry, water treatment and distribution, food industry, chemical and petrochemical industries, power industry etc.

Design features and advantages of using:

- bi-directional permanent tightness
- low pressure drop
- short face to face dimension
- light weight
- low torque
- wide range of materials of bodies, discs, liners
- all valve components can be dismantled
- replaceable parts are interchangeable with other types of valves in production range
- various types of operating
- easy installation and maintenance
- reliable and long life service



Údaje uvedené v katalogu jsou informativní a výrobce si vyhrazuje právo na technické změny.
Catalogue is for information only and manufacturer reserves the right to changes of technical details.

KONSTRUKCE

COMPONENTS

Hlavní konstrukční části uzavírací klapky jsou těleso, disk, manžeta, hřídel, uložení a těsnění hřídele.

The main components of butterfly valves are body, disc, liner, shaft, bushing and sealing of shaft.

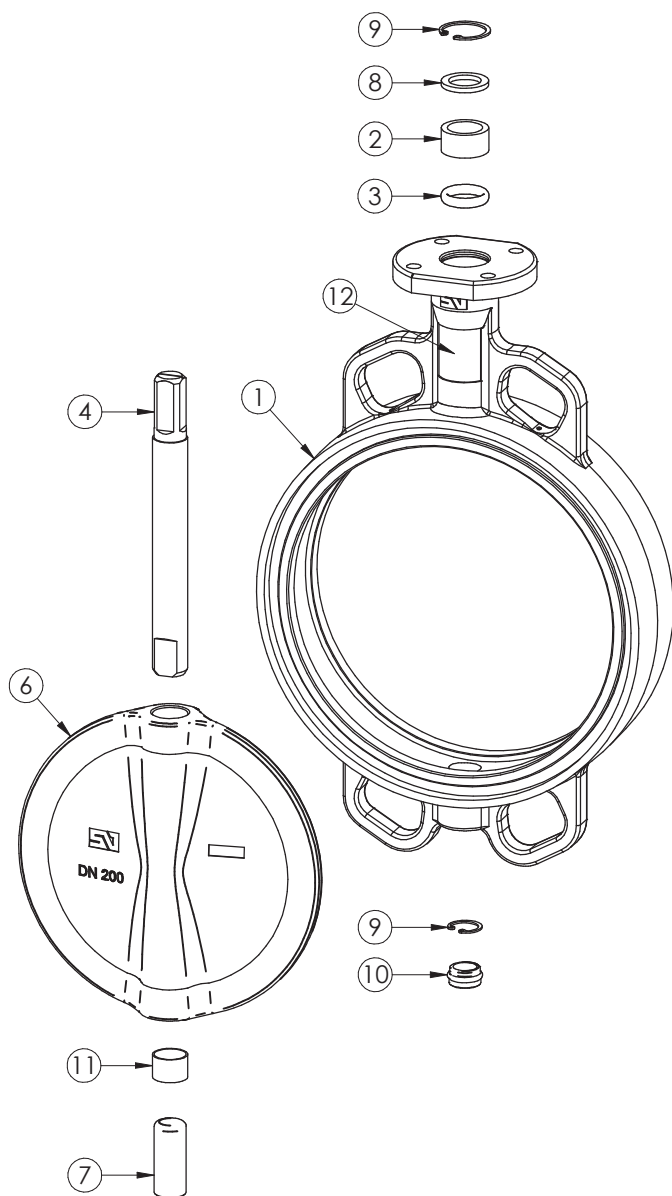

ČÍSLO NUMBER	POPIS	DESCRIPTION
1	Těleso	Body
2	Uložení hřídele	Bushing
3	O-kroužek	O-ring
4	Horní hřídel	Upper shaft
5	Manžeta	Liner
6	Disk	Disc
7	Dolní hřídel	Lower shaft
8	Kluzná podložka	Retaining ring
9	Pojistný kroužek	Zegi ring
10	Zátka	Lower plug
11	Uložení hřídele	Bushing
12	Informační štítek	Featuring tag

Jednotlivé typy těles, materiálové varianty těles, disků a manžet jsou uvedeny v příslušných tabulkách na následujících stránkách.

The individual design, material variations of bodies, discs and liners are presented in the charts on following pages.

SKLADBA KATALOGOVÉHO ČÍSLA

CATALOGUE NUMBER

FLW - 3 - 150 - MN - E / PN

o typ tělesa/označení Type of Body/Code	o disk Disc	o nominální průměr Nominal Diameter DN 25 (1") ÷ 1 600 (64")	o způsob ovládání Operating	o manžeta Liner	o norma vrtání přírub Drilling Norm ¹⁾ PN 6/10/16/25
--	----------------	--	--------------------------------	--------------------	---

¹⁾ Neznamená vždy maximální dovolený pracovní přetlak! Maximální pracovní zatížení u jednotlivých typů uzavíracích klapek je uvedené v příslušných katalogových listech./

It doesn't always mean allowed maximum working pressure! The maximum working load for each type of butterfly valve is shown in the relevant data sheets.

TĚLESO / BODY				
TYP TĚLESA / TYPE OF BODY	OZNAČENÍ / CODE	DN	PN	MATERIÁL TĚLESA / MATERIAL OF BODY
FL(W) bez přírub / Wafer	FLW	025-150	16	Šedá litina / Grey cast iron EN GJL-250 ²⁾
		200-1200	10	
	FLNW	025-150	16	Tvárná litina / Nodular cast iron EN GJS 400-15 ²⁾
		200-1200	16 ³⁾	
LUG(W) se závitovými oky / with threaded eyes (LUGGED)	LUGW	025-150	16	Šedá litina / Grey cast iron EN GJL-250 ²⁾
		200-1000	10	
	LUGNW	025-150	16	Tvárná litina / Nodular cast iron EN GJS 400-15 ²⁾
		200-1000	16 ³⁾	
LUGAW	025-1000	16	Uhlíková ocel / Carbon Steel	
	025-300	25 ³⁾	ASTM A216 WCB ²⁾ (EN 10025 S275 JR)	
FG(W) přírubové / Flanged	FGW	150	16	Šedá litina / Grey cast iron EN GJL-250 ²⁾
		200-1600	10	
	FNW	150	16	Tvárná litina / Nodular cast iron EN GJS 400-15 ²⁾
		200-1200	16 ³⁾	
FGAW	150-1200	16	Uhlíková ocel / Carbon Steel	
	150-300	25 ³⁾	ASTM A216 WCB ²⁾ (EN 10025 S275 JR)	
KL bez přírub / Wafer	KL	050-500	6/10/16	Al slitina / Aluminium alloy EN AC 47100 / EN AC 46100 ²⁾
BBNV (W) přírubové / Flanged	BBNVW	040-150	16	
		200-1200	10	Tvárná litina / Ductile cast iron EN GJS 400-15 ²⁾
		200-1200	16 ³⁾	
FFNV (W) přírubové / Flanged	FFNVW	400-1000	10	Tvárná litina / Ductile cast iron EN GJS 400-15 ²⁾
VV s drážkami pro připojení rychloupínacími objímkami / with grooved ends	VV	050-200	16	Tvárná litina / Ductile cast iron EN GJS 400-15 ²⁾

²⁾ S ochranným epoxidovým povlakem certifikovaným DVGW, KTW a W20. Jiné druhy nátěrů (včetně těžké protikorozní ochrany litinových prvků podle GSK) na přání. / With a protective epoxy coating certified by DVGW, KTW and W20. Other types of coatings (including heavy corrosion protection of cast iron elements according to GSK) on request.

³⁾ Na přání / On request

DISK / DISC

TYP / TYPE	MATERIÁL / MATERIAL	PODLE NORMY / ACC. TO STD.
1	Nerezová ocel litá / Stainless steel	ASTM A351 / A351M CF8
2	Al slitina / Aluminium Alloy ²⁾	EN AC 44100
3	Tvárná litina / Nodular cast iron ²⁾	EN GJS 400-15
4	Sn/ Al bronz / Sn Al Bronze	EN 1982 CuSn10-C / CuAl10Fe5Ni5-C
5	Nerezová ocel litá / Stainless steel	ASTM A351 / A351M CF8M
6	Uhlíková ocel litá / Carbon steel	ASTM A216 / A216M WCB
7	Tvárná litina + EPDM / Nodular cast iron+EPDM	EN GJS 400-15 + EPDM
8	Duplexní nerezová ocel / Duplex	NORIDUR ASTM A743 / A743M CD4MCuN
9	Austenitická nerezová ocel / Austenitic stainless st.	URANUS B6 (904L)
10	Superduplexní nerezová ocel / Superduplex	1.4469

POVRCHOVÁ OCHRANA / COATINGS

Těleso a disk se dodávají s těmito možnými druhy povrchové ochrany:

- Epoxidový povlak
- Rilsan (Polyamid 11)
- Halar (Fluoropolymer)
- Jiný druh na přání

The body as well as the disc can be coated / treated with:

- Epoxy resin
- Rilsan (Polyamide 11)
- Halar (Fluoropolymer)
- Other under request

Materiály manžety / Materials of liners	Označení Technical code	Zkrácené označení Code	Min./max. pracovní teplota Min./max. working temperature
Ethylen propylen / Ethylene Propylene	EPDM	E	- 20 °C + 110 °C
Vysokoteplotní ethylen propylen / Ethylene Propylene High T.	EPDM	HT	+ 80 °C + 130 °C
Potravinářský ethylen propylen / Food EPDM (FDA)	EPDM	EF	- 20 °C + 110 °C
Bílý potravinářský EPDM / Food White EPDM (FDA)	EPDM	EB	- 20 °C + 95 °C
EPDM certifikovaný (DVGW ACS, WRAS, KTW, W270)	EPDM	EW	- 20 °C + 95 °C
Nitril / Nitrile	NBR	N	- 10 °C + 90 °C
Potravinářský nitril / Food Nitrile (FDA)	NBR	NB	- 10 °C + 90 °C
Hydrogenovaný nitril / Nitrile Hydrogenated	NBR	NH	- 10 °C + 90 °C
Polisoprén AB/P / Flucast AB/P	-	AP	- 10 °C + 70 °C
Polisoprén AB/E / Flucast AB/E	-	AE	- 20 °C + 95 °C
Polisoprén AB/N / Flucast AB/N	-	AN	- 10 °C + 100 °C
Silikon / Silicone	WVQ	S	- 60 °C + 200 °C
Potravinářský silikon / Food Silicone	WVQ	SA	- 60 °C + 200 °C
Silikon na páru / Steam Silicone	WVQ	SV	- 60 °C + 140 °C
Viton	FPM	V	- 15 °C + 210 °C
Viton Bio	FPM	VB	- 5 °C + 210 °C
Viton GF	FPM	VF	- 5 °C + 210 °C
Hypalon	CSM	H	- 25 °C + 125 °C
Epichlorhydrin / Epichlorhydrine	ECO	ECO	- 40 °C + 125 °C

Pozn: Uvedené rozsahy pracovních teplot jsou pouze orientační. Za účelem výběru vhodné manžety na konkrétní médium a teplotu, prosíme, kontaktujte naše obchodní oddělení.

Note: Mentioned range of working temperatures is for orientation only. Please contact our Sales Department in order to determine suitable material of liner for specific working medium and temperature.

OVLÁDÁNÍ / OPERATING

TYP / TYPE	OVLÁDÁNÍ / OPERATING
EL	bez ovládání / bare shaft
MN	ruční páka se zarážkami po 15° / hand lever with notches of 15°
MR	ruční páka s možností blokace v jakékoliv pozici / hand lever with blocking in all positions
MDV	převod s ručním kolem / gearbox with hand wheel
MND	pneumatický pohon dvojitý / double acting pneumatic actuator
MNS	pneumatický pohon s vratnou pružinou / single acting pneumatic actuator
MSE	elektrický pohon / electric actuator

HŘÍDEL / SHAFT

MATERIÁL / MATERIAL: NEREZOVÁ OCEL / STAINLESS STEEL ASTM A276 AISI 420	
DN ≤ 500	se čtyřhranem pro připojení ovládání / with square end
DN ≥ 600	s připojením pero-drážka / keyway

ULOŽENÍ A TĚSNĚNÍ HŘÍDELE / BEARING AND SEALING OF SHAFT

Materiál závisí na max. pracovní teplotě / Material depending on the max. working temperature.	
Uložení / Bearing	Acetal polymer, bronz nebo ocel-bronz-PTFE / Acetyl, bronze or steel-bronze-PTFE
O-kroužky / O-rings	NBR nebo / or VITON

ZKOUŠENÍ / TESTING

Uzavírací klapky se zkoušejí podle normy EN 12266-1 P10, P11, P12 a dodávají s průvodní dokumentací podle EN 10204
Butterfly valves are tested acc. to EN 12266-1 P10, P11, P12 and supplied with documentation acc. to EN 10204

CERTIFIKACE / CERTIFICATION

PED 2014/68/EU (PED 97/23/CE)

ATEX (II2GD) 94/9/CE

DWGV: Schválení pro použití na pitnou vodu nebo plyn / Approval for use on potable water or gas

PRŮTOKOVÁ CHARAKTERISTIKA

HEAD LOSS DIAGRAM

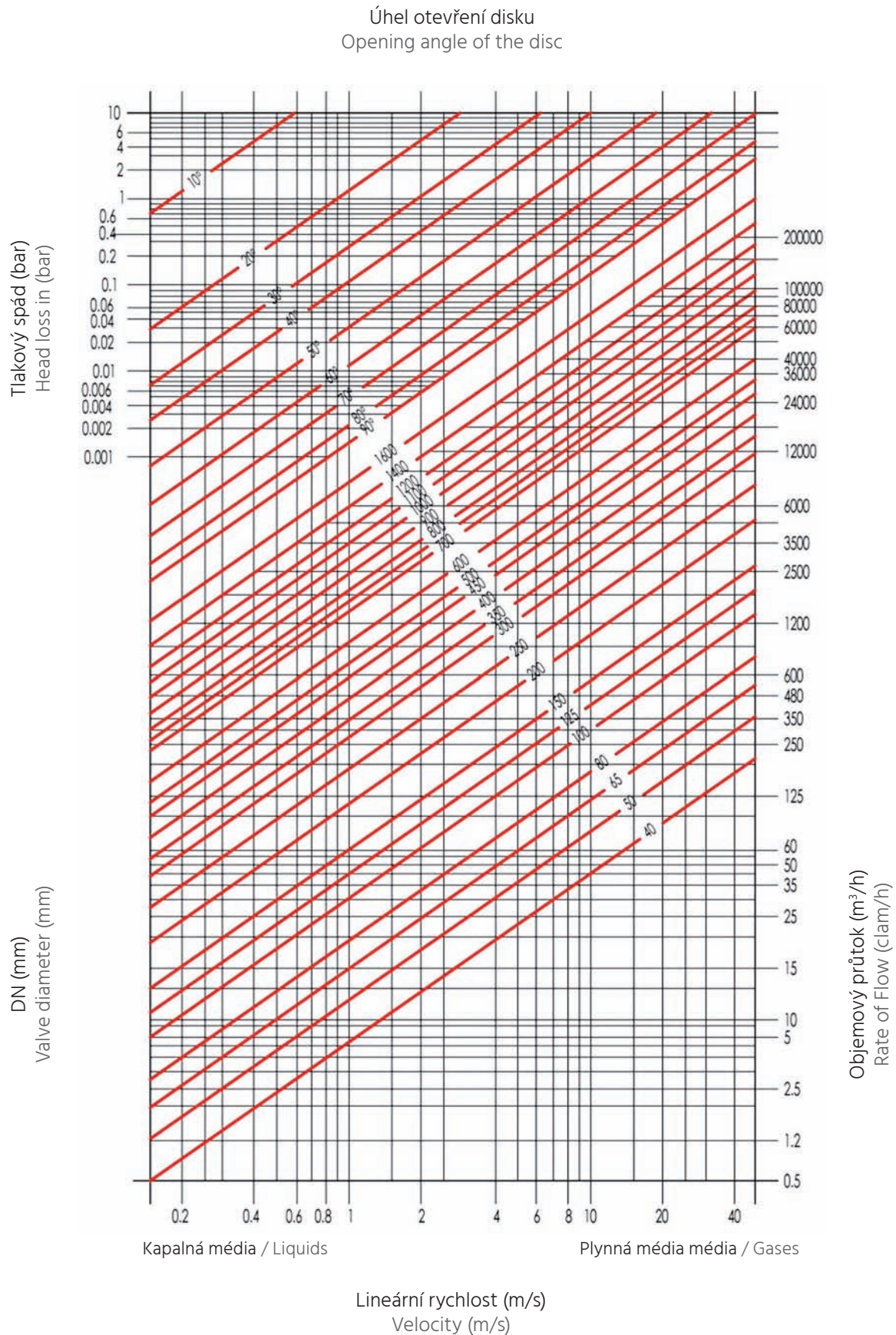

TECHNICKÉ ÚDAJE

TECHNICAL DATA

OVLÁDACÍ MOMENT (v Nm) POTŘEBNÝ NA UZAVŘENÍ Klapky V ZÁVISLOSTI NA TLAKOVÉM ROZDÍLU ΔP					
NECESSARY TORQUE (in Nm) FOR CLOSING OF THE VALVE DEPENDING ON DIFFERENTIAL PRESSURE ΔP					
DN		3 bar	6 bar	10 bar	16 bar
mm	inch				
25	1"	5	6	9	15
32	1 1/4"	5	6	9	15
40	1 1/2"	5	6	9	15
50	2"	5	7	13	17
65	2 1/2"	15	16	20	25
80	3"	17	20	23	28
100	4"	22	29	42	50
125	5"	39	46	72	85
150	6"	48	75	90	110
200	8"	90	120	140	215
250	10"	126	210	270	350
300	12"	161	270	390	560
350	14"	245	300	500	950
400	16"	520	600	700	1 000
450	18"	590	1 120	1 450	1 950
500	20"	840	1 390	1 800	2 500
600	24"	1 000	2 200	3 450	3 800
700	28"	1 650	3 300	5 000	5 860
750	30"	1 800	3 500	5 500	6 000
800	32"	2 300	4 600	6 500	9 500
900	36"	4 700	6 800	8 500	11 500
1 000	40"	6 500	8 500	11 500	15 000
1 100	44"	7 000	9 000	12 000	16 000
1 200	48"	8 500	12 000	15 500	22 000
1 400	56"	14 000	17 000	19 500	
1 500	60"	20 000	24 000	28 000	
1 600	64"	22 000	26 000	30 000	

Pozn:

Ovládací momenty uvedené v barevně vyznačených polích platí pro běžně dodávané uzavírací klapky se standardním a měkkými manžetami EPDM nebo NBR, které pracují s kapalnými pracovními médii. Pro jiné (tvrdší) materiály manžet a suchá pracovní média se hodnoty ovládacích momentů oproti uvedeným výrazně mění.

Na přání lze dodat klapku s diskem opracovaným pro konkrétní maximální pracovní tlak. Potom je rozhodující pro určení hodnoty ovládacího momentu přesah (nebo redukce) disku. Proto, prosíme, při navrhování vhodného ovládacího a dimenzování elektrického, pneumatického nebo hydraulického pohonu kontaktujte naše obchodní oddělení.

Note:

The torques mentioned in colour boxes are applicable for common butterfly valves with standard disc and soft EPDM or NBR liners working with liquids only. In case of other materials (harder) of liners or dry working media, the torques could change significantly.

It is possible to deliver butterfly valve with disc modified for specific maximum working pressure. The size of overlap (or reduction) of disc determines the size of torque. Please contact our Sales Department for design of suitable electric, pneumatic or hydraulic actuator.

UZAVÍRACÍ KLAPKY TYP FL(W) / VALVES TYPE FL(W)



Typ tělesa / Body type	bezpřírubové / WAFER
Rozsah DN / Production Range	DN 25–1 200
Konstrukce / Standard Design	EN 593
Stavební délka / Face to Face	EN 558-1 řada / serie 20 (DIN 3202 T3 K1) ISO 5752 T5 - krátká / short type API 609, BS 5155 series/ řady 4-5 vyjma / except DN350
Vrchní příruba / Top Flange	EN ISO 5211 / NFE 29-402
Vrtání přírub / Drilling Norm	DIN PN 10/16, ANSI cl. 150
Norma označení / Marking	EN 19
Max. pracovní tlak / Max. working pressure	16 bar DN 25–150 10 bar DN 200–1200 (16 bar - na přání / on request)
Pracovní teplota / Working temperature	-40 °C + 210 °C
Zkoušky armatur / Hydraulic tests	EN 12266 / ISO 5208

Tato vysoce kvalitní bezpřírubová uzavírací klapka v moderním a neustále zdokonalovaném provedení je určena pro široké průmyslové použití, především ve vodárenství a topenářství. Těleso s prodlouženým krkem dovoluje dodatečně tepleně izolovat potrubí, ovšem volný přístup k ovládání klapky zůstane zachován.

High quality and ever-improving modern design determine this butterfly valve for wide industrial application, especially in water supplies and heating systems. The body is clearly different due to its extended neck allowing pipe insulation with still free access to the actuator.

Oblasti použití / Applications



- Čištění úprava a rozvody vody /pitné vody
- Rozvody teplé vody, větrání a klimatizace
- Rozvody hasící vody
- Lodní průmysl
- Zavlažovací systémy
- Přeprava suchých a práškových směsí

- Water treatment plants and water/ potable water distribution
- HVAC (Heat Ventilation Air Conditioning)
- Fire fighting
- Shipbuilding
- Irrigation
- Powdery products transport

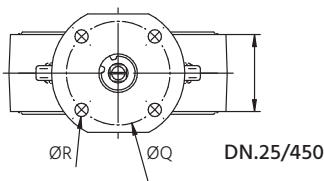
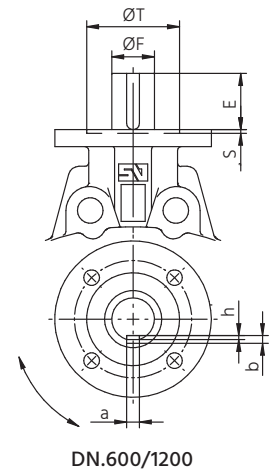
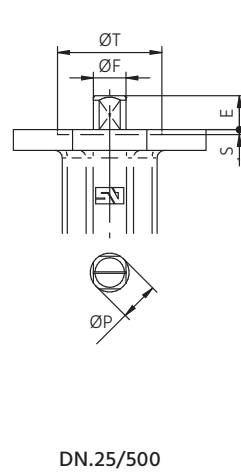
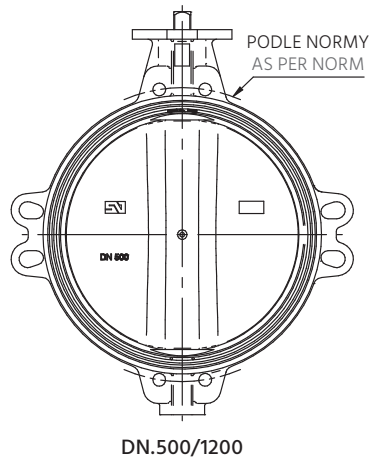
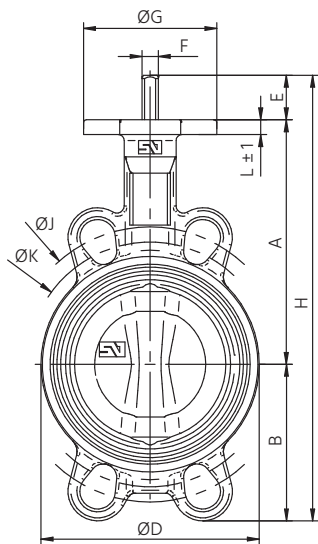

DN		ZÁKLADNÍ ROZMĚRY / GENERAL DIMENSIONS											VRCHNÍ PŘÍRUBA / TOP FLANGE				
mm	inch	A	B	C	D	E	F	G	H	J	K	Kg	ISO	Q	R	S	T
25	1"	102,5	60,2	33	68	30	11	90	192,7	100	85	1,5	F-07	70	4×9		
32	1 1/4"	102,5	60,2	33	68	30	11	90	192,7	100	85	1,5	F-07	70	4×9		
40	1 1/2"	110	56	33	76	30	11	90	196	110	95	1,6	F-07	70	4×9		
50	2"	120	61,5	43	100	30	11	90	211,5	123	120,6	2,4	F-07	70	4×9		
65	2 1/2"	135	69	46	108	30	11	90	234	145	127	2,7	F-07	70	4×9		
80	3"	141	94	46	124	30	11	90	265	160	145	3,2	F-07	70	4×9		
100	4"	165	106	52	147	30	11	90	301	185,5	165	4,0	F-07	70	4×9		
125	5"	180	126,5	56	180	33	14	90	339,5	225	206	6,2	F-07	70	4×9		
150	6"	193	133	56	206	33	14	90	359	241,3	229	7,3	F-07	70	4×9		
200	8"	225	170	60	257	33	17	90	428	305	280	11,1	F-07	70	4×9		
250	10"	282,5	210	68	324	23	22	130	515,5	362	335	20,2	F-10	102	4×12	3	70
300	12"	308	240	78	376	23	22	130	571	431,8	394	29,6	F-10	102	4×12	3	70
350	14"	338,5	263	78	422	31	22	160	632,5	476,3	445	35,2	F-10	102	4×12	3	70
400	16"	380	308	102	480	31	27	160	719	540	510	55,5	F-12	125	4×14	4	85
450	18"	380,5	340	114	536	38	36	190	758,5			79,7	F-14	140	4×18	4	100
500	20"	432,5	380	127	593	38	36	210	850,5			114	F-14	140	4×18	4	100
600	24"	494	440	154	690	80	60	210	1 014			170,9	F-16	165	4×22	5	130
700	28"	590	490	165	830	106	65	300	1 186			252,9	F-25	254	8×18	5	200
750	30"	590	530	190	836	106	80	300	1 226			294,9	F-25	254	8×18	5	200
800	32"	630	565	190	902	106	80	300	1 301			346,5	F-25	254	8×18	5	200
900	36"	695	610	203	1 010	110	80	350	1 415			459,5	F-25	254	8×18	5	200
1 000	40"	770	675	216	1 116	110	80	350	1 555			580,7	F-25	254	8×18	5	200
1 100	44"	815	733	216	1 215	110	80	350	1 658			715,5	F-25	254	8×18	5	200
1 200	48"	875	818	254	1 334	110	100	350	1 803			963,3	F-30	298	8×23	5	230

ROZMĚRY S OVLÁDÁNÍM / DIMENSIONS WITH OPERATING

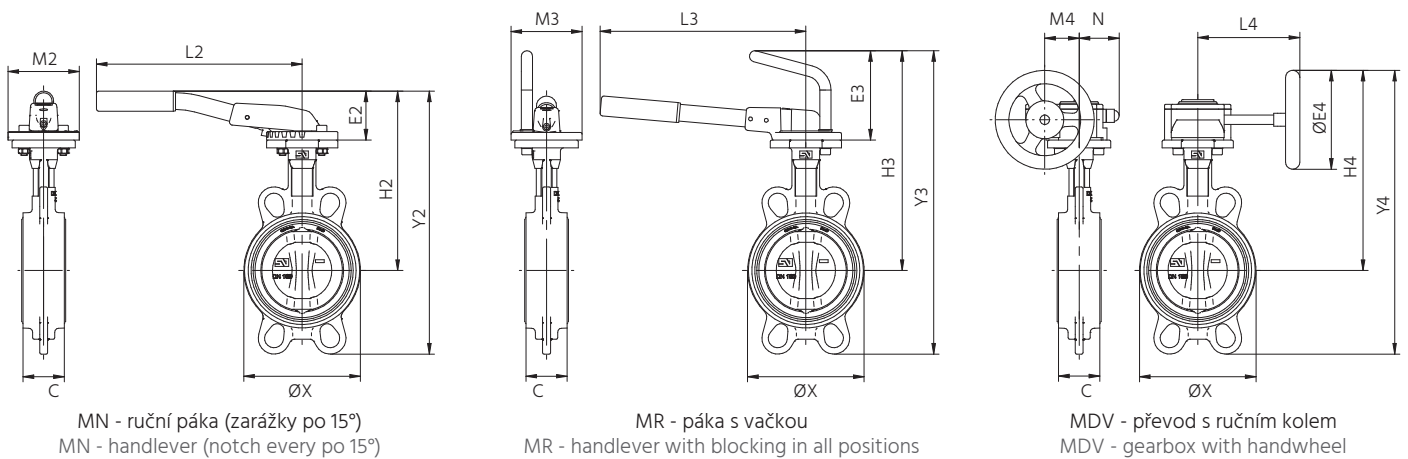

DN		MN									MR						MDV							
mm	Inch	C	X	E2	H2	Y2	L2	M2	Kg	E3	H3	Y3	L3	M3	Kg	REF	E4	H4	Y4	L4	M4	N	Kg	
25	1"	33	68	49	151,5	211,7	220	90	1,9	113	215,5	276	260	90	2,1	0	125	190,5	250,8	129	43,5	50,5	2,7	
32	1 1/4"	33	68	49	151,5	211,7	220	90	1,9	113	215,5	276	260	90	2,1	0	125	190,5	250,8	129	43,5	50,5	2,7	
40	1 1/2"	33	76	49	159	215	220	90	2,0	113	223	279	260	90	2,3	0	125	198	254	129	43,5	50,5	2,8	
50	2"	43	100	49	169	230,5	220	90	2,8	113	233	294,5	260	90	3,1	0	125	208	269,5	129	43,5	50,5	3,6	
65	2 1/2"	46	108	49	184	253	220	90	3,1	113	248	317	260	90	3,4	0	125	223	292	129	43,5	50,5	3,9	
80	3"	46	124	60	201	295	260	90	3,7	113	254	348	260	90	3,9	0	125	229	323	129	43,5	50,5	4,4	
100	4"	52	147	60	225	331	260	90	4,5	113	278	384	260	90	4,7	0	125	253	359	129	43,5	50,5	5,2	
125	5"	56	180	75	255	381	315	90	6,8	113	293	419,5	310	90	6,9	1	160	285,5	412	135	43,5	50,5	7,6	
150	6"	56	206	75	268	401	315	90	7,9	113	306	439	310	90	8,0	1	160	298,5	431,5	135	43,5	50,5	8,7	
200	8"	60	257	75	300	470	315	90	11,7	113	338	508	310	90	11,8	1A	200	355	525	152	52,5	59	13,7	
250	10"	68	324							121	403,5	613,5	500	130	21,9	2	250	442,5	652,5	222	61,2	70,5	23,7	
300	12"	78	376							121	429	669	500	130	31,3	2	250	468	708	222	61,2	70,5	33,1	
350	14"	78	430							121	459,5	722,5	500	130	36,9	2	250	498,5	761,5	222	61,2	70,5	38,7	
400	16"	102	485													2A	300	572,5	880,5	278	68,8	72,5	64,4	
450	18"	114	536							3	400	630,5	970,5	321	96,5	91,5	98,1							
500	20"	127	593							3	400	682,5	1063	321	96,5	91,5	132							
600	24"	154	690							4	500	798,5	1239	408	137,5	140	205							
700	28"	165	830							4	600	944,5	1435	424	137,5	140	288							
750	30"	190	836							5	600	944,5	1475	456	137,5	140	336							
800	32"	190	902							5	600	984,5	1550	456	137,5	140	388							
900	36"	203	1010							6	700	1109	1719	510	180	156	520							
1000	40"	216	1116							7	700	1184	1859	579	180	156	647							
1100	44"	216	1215							7	700	1229	1962	579	180	156	782							
1200	48"	254	1334							8	700	1310	2128	593	252	228	1159							

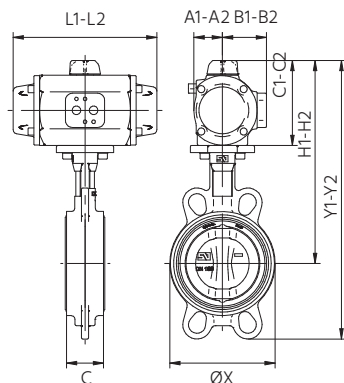

DN		2-ČINNÝ / DOUBLE ACTING										1-ČINNÝ / SPRING RETURN											
mm	Inch	C	X	REF	A1	B1	C1	H1	Y1	L1	Kg1	REF	A2	B2	C2	H2	Y2	L2	Kg2				
25	1"	33	68	PA00	31,9	52,2	120,5	223	283,3	152,8	2,9	PA00S	31,9	52,2	120,5	223	283,3	152,8	3,1				
32	1 1/4"	33	68	PA00	31,9	52,2	120,5	223	283,3	152,8	2,9	PA00S	31,9	52,2	120,5	223	283,3	152,8	3,1				
40	1 1/2"	33	76	PA00	31,9	52,2	120,5	230,5	286,5	152,8	3,0	PA00S	31,9	52,2	120,5	230,5	286,5	152,8	3,2				
50	2"	43	100	PA00	31,9	52,2	120,5	240,5	302	152,8	3,8	PA00S	31,9	52,2	120,5	240,5	302	152,8	4,0				
65	2 1/2"	46	108	PA05	39,9	61,7	119	254	323	201,2	5,3	PA05S	39,9	61,7	119	254	323	201,2	5,6				
80	3"	46	124	PA05	39,9	61,7	119	260	354	201,2	5,8	PA10S	40,9	62,7	123	264	358	225	6,7				
100	4"	52	147	PA05	39,9	61,7	119	284	390	201,2	6,6	PA15S	48,9	70,5	138,6	303,6	409,5	265	9,0				
125	5"	56	180	PA10	40,9	62,7	123	303	429,5	225	9,3	PA20S	52,4	75,1	146,8	326,8	453,2	310	12,8				
150	6"	56	206	PA15	48,9	70,5	138,6	331,6	464,5	265	11,5	PA25S	64,3	89,2	174,8	367,8	500,7	358,2	18,6				
200	8"	60	257	PA20	52,3	75,1	146,8	371,8	541,7	310	16,7	PA30S	71,7	97,3	191,3	416,3	586,3	427,5	26,4				
250	10"	68	324	PA25	64,2	89,2	174,8	457,2	667,2	358,2	29,5	P40S	106	120	272	554,5	764,5	598	56,6				
300	12"	78	376	PA30	71,7	97,3	191,3	499,3	739,3	427,5	41,2	P40S	106	120	272	580	820	598	66,0				
350	14"	78	430	P40	106	120	272	610,5	873,5	444	52,8	P40S	106	120	272	610,5	873,5	598	71,6				
400	16"	102	485	P40	106	120	272	652	960	444	73,1	P50S	122,5	135	383	763	1071	694	116				
450	18"	114	536	P50	122,5	135	313	693,5	1033	524	110	PA60S	158,5	172	438	818,5	1158	672,5	165				
500	20"	127	593	P50	122,5	135	313	745,5	1125	524	145	PA70S	186	217	498	930,5	1310	742,5	232				
600	24"	154	690	PA60	158,5	172	368	862	1302	672,5	219												
700	28"	165	830	PA70	186	217	453	1043	1533	742,5	343												
750	30"	190	836																				
800	32"	190	902																				

MOŽNOSTI MONTÁŽE MEZI PŘÍRUBY / POSSIBILITIES OF ASSEMBLY BETWEEN FLANGES

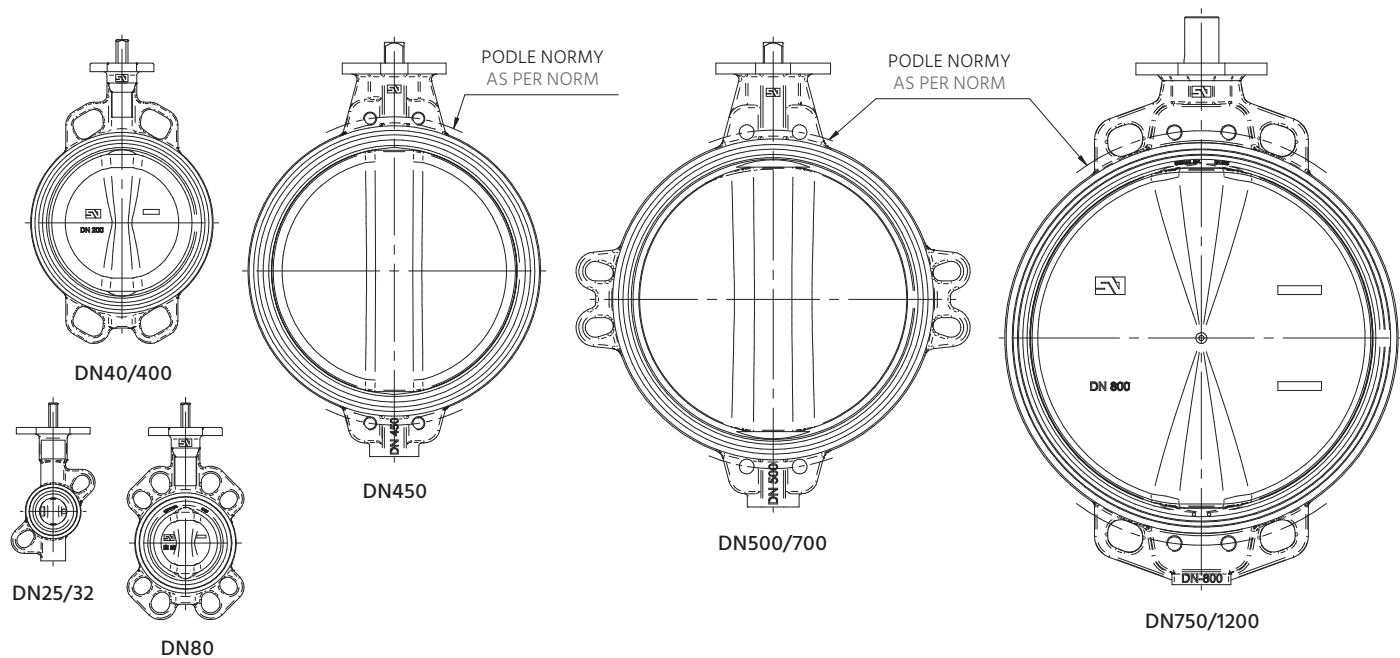

DN	25	32	40	50	65	80	100	125	150	200	250	300	350	400	450	500	600	700	750	800	900	1000	1100	1200
PN.6	o	x	x	o	x	x	x	x	x	x	x	x	x	o	o	o	o	-	x	o	o	o	o	o
PN.10	x	x	x	x	x	x	x	x	x	x	x	x	x	x	x	x	x	x	x	x	x	x	x	x
PN.16	x	x	x	x	x	x	x	x	x	x	x	x	x	x	x	x	x	x	x	x	x	x	x	x
PN.20	o	x	x	x	x	x	x	x	x	x	x	x	x	x	x	x	x							
ANSI 150 Lbs	o	x	x	x	x	x	x	x	x	x	x	x	x	x	x	x	x	o	x	x	x	o	o	o
AWWA							x	x	x	x	x	x	x	x	x	x	x	o	x	x	x	o	o	o
ASME B16.47a-150																		o	x	x	x	o	o	o
ASME B16.47a-300																		-	-	-	-	o	x	x
ASME B16.47b-150																		-	o	o	o	o	o	o
ASME B16.47b-300																		o	o	o	x	o	o	o
BS, D	o	x	x	o	x	x	x	x	x	x	o	x	x	o	x	o	o			o				x
BS, E	o	x	x	o	x	x	x	x	x	x	x	x	o	x	o	o	o			o				x
JIS 5k	o	x	x	-	x	x	x	x	x	x	x	x	o	o	o	o	o	o	x	o	o	o	o	o
JIS 10k	o	x	x	x	x	x	x	x	x	x	x	o	x	x	x	x	x	x	x	o	x	x	x	x
JIS 16k	o	x	x	o	o	x	x	x	o	x	o	o	o	x	x	x	x	-	x	x	x	x	x	x
AS 2129 E	o	x	x	o	x	x	x	x	x	x	x	x	x	o	x	o	o	o	o	o	o	o	o	x

X STANDARDNÍ / STANDARD
 O NA VYŽÁDÁNÍ / ON REQUEST
 - NENÍ MOŽNÉ / NOT POSSIBLE

MONTÁŽ MEZI PŘÍRUBY / ASSEMBLY BETWEEN FLANGES

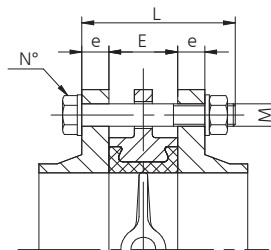
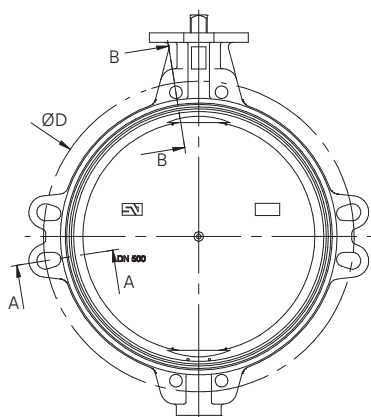

A-A ŠROUB / SCREW

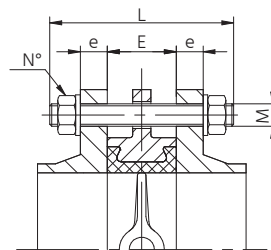

A-A SVORNÍK / LINK

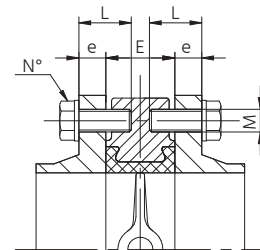

B-B ŠROUBY / SCREWS ONLY

Závitové otvory pro montáž mezi přírby se závity:

- metrickými (PN 10/16)
- UNC (ANSI 150)
- ostatní typy na přání

Threaded holes for the assembly between flanges will be:

- metric thread standards for pn. norms:
- UNC thread standards for ANSI 150 norms
- other thread on request

DN	E	PN10						PN16						ANSI 150 Lbs					
		D	e	M	L	L1	N°	D	e	M	L	L1	N°	D	e	M	L	L1	N°
25	33	85	16	M12	90	110	4	85	16	M12	90	110	4	79,4	14,3	1/2"	85	105	4
32	33	100	16	M16	90	110	4	100	16	M16	90	110	4	88,9	17,5	1/2"	90	110	4
40	33	110	16	M16	90	110	4	110	16	M16	90	110	4	98,4	17,5	1/2"	90	110	4
50	43	125	18	M16	100	120	4	125	18	M16	100	120	4	120,6	19	5/8"	100	120	4
65	46	145	18	M16	100	120	4	145	18	M16	100	120	4	139,7	22,2	5/8"	110	130	4
80	46	160	20	M16	110	130	8	160	20	M16	110	130	8	152,4	23,8	5/8"	110	130	4
100	52	180	20	M16	110	130	8	180	20	M16	110	130	8	190,5	23,8	5/8"	120	140	8
125	56	210	22	M16	120	140	8	210	22	M16	120	140	8	215,9	23,8	3/4"	130	150	8
150	56	240	22	M20	130	150	8	240	22	M20	130	150	8	241,3	25,4	3/4"	130	150	8
200	60	295	24	M20	130	160	8	295	24	M20	130	160	12	298,5	28,6	3/4"	140	160	8
250	68	350	26	M20	150	170	12	355	26	M24	150	170	12	361,9	30,2	7/8"	160	180	12
300	78	400	26	M20	160	180	12	410	28	M24	160	180	12	431,8	31,7	7/8"	170	190	12
350	78	460	26	M20	170	180	16	470	30	M24	170	190	16	476,2	34,9	1"	180	200	12
400	102	515	26	M24	180	210	16	525	32	M27	200	220	16	539,7	36,5	1"	210	230	16
450	114	565	26	M24	190	220	16	585	32	M27	210	240	16	277,8	39,7	1 1/8"	230	250	16
				M24	60	220	8			M27	60	240	8						
500	127	620	28	M24	210	230	20	650	34	M30	230	260	20	635,0	46	1 1/8"	250	280	16
																1 1/8"	105	8	
600	154	725	28	M27	240	270	20	770	36	M33	260	290	20	749,3	47,6	1 1/4"	280	310	20
				M27	260	280	20			M33	270	300	20			1 1/4"	310	340	24
700	165	840	30	M27	80	280	8	840	36	M33	85	300	8	863,5	52,5	1 1/4"	110	8	
																1 1/4"	110	8	
750	190	900	32	M30	290	320	20	900	38	M33	300	340	20	914,4	54	1 1/4"	335	24	
				M30	95	320	8			M33	100	340	8			1 1/4"	110	375	8
800	190	950	32	M30	290	320	20	950	38	M36	310	345	20	978	57	1 1/2"	340	24	
				M30	110	320	8			M36	80	345	8			1 1/2"	95	380	8
900	203	1050	34	M30	310	350	24	1050	40	M36	330	375	24	1086	60	1 1/2"	370	28	
				M30	100	350	8			M36	100	375	8			1 1/2"	110	415	8
1000	216	1160	34	M33	325	360	24	1170	42	M39	345	390	24	1200	63,5	1 1/2"	390	32	
				M33	95	360	8			M39	100	390	8			1 1/2"	120	430	8
1100	216	1270	38	M33	330	370	28	1270	48	M39	360	400	28	1314,5	101	1 1/2"	465	36	
				M33	100	370	8			M39	110	400	8			1 1/2"	150	410	8
1200	254	1380	38	M36	375	420	28	1390	48	M45	395	445	28	1422	108	1 1/2"	475	40	
				M36	110	420	8			M45	115	445	8			1 1/2"	165	520	8

UZAVÍRACÍ KLAPKY TYP LUG(W) / VALVES TYPE LUG(W)



Typ tělesa / Body type	se závitovými oky / LUGGED
Rozsah DN / Production Range	DN 25–1 000
Konstrukce / Standard Design	EN 593
Stavební délka / Face to Face	EN 558-1 řada / serie 20 (DIN 3202 T3 K1) ISO 5752 T5 krátká / short type API 609, BS 5155 řady / series 4-5, vyjma / except DN350
Vrchní příruba / Top Flange	EN ISO 5211 / NFE 29-402
Vrtání přírub / Drilling Norm	DIN PN 10/16, ANSI cl. 150
Norma označení / Marking	EN 19
Max. pracovní tlak Max. working pressure	16 bar DN 25–150 10 bar DN 200–1000 (16 bar - na přání / on request)
Pracovní teplota / Working temperature	-40 °C + 210 °C
Zkoušky armatur / Hydraulic tests	EN 12266 / ISO 5208

Uzavírací klapky se závitovými oky jsou určeny pro průmyslové použití, především v plynárenství a vodárenství, kde závitová oka u menších dimenzí klapek nahrazují příruby. Výhodou je zároveň i možnost použít tento typ klapky jako koncové armatury, např. na výstupu čerpadel a cisteren nebo na boku lodí.

The LUG(w) series is designed for industrial applications, and substitutes double flanged valves, specially in small diameters. It offers considerable advantages where dead-end services are needed, such as pump outlets, tanks and ship sides.

Oblasti použití / Applications



- Rozvody plynu
- Čištění úprava a rozvody vody/ pitné vody
- Chadící systémy
- Rozvody hasicí vody
- Vytápění
- Lodní průmysl

- Gas distribution
- Water treatment plants and water/ potable water distribution
- Cooling systems
- Fire fighting
- Heating
- Shipbuilding

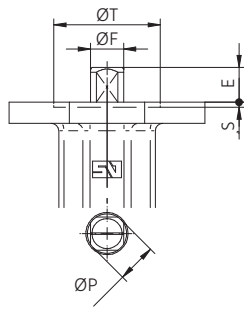
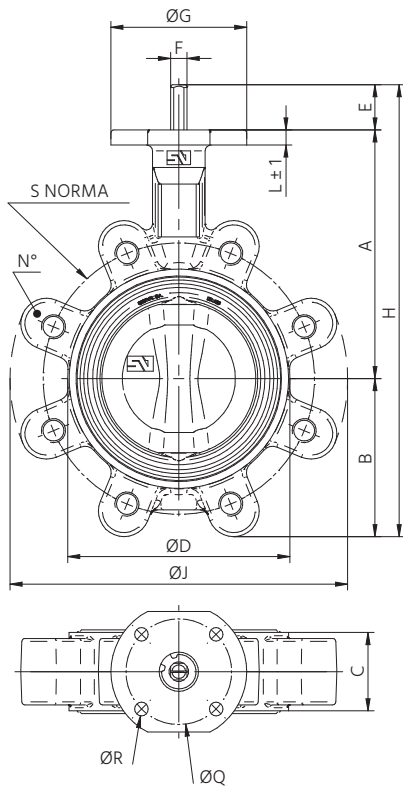

DN25/500

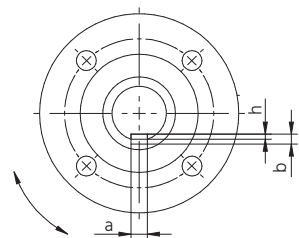
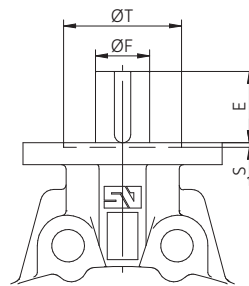

DN600/1000

DN			ZÁKLADNÍ ROZMĚRY // GENERAL DIMENSIONS											VRCHNÍ PŘÍRUBA / TOP FLANGE				
mm	inch	N°	A	B	C	D	E	F	G	H	J	Kg	ISO	Q	R	S	T	
25	1"	4	102,5	50,4	33	68	30	11	90	183	130	1,85	F-07	70	4×9			
32	1 1/4"	4	102,5	50,4	33	68	30	11	90	183	130	1,85	F-07	70	4×9			
40	1 1/2"	4	110	54	33	76	30	11	90	194	140	2,0	F-07	70	4×9			
50	2"	4	120	59,5	43	100	30	11	90	209,5	156	2,9	F-07	70	4×9			
65	2 1/2"	4	135	66,5	46	108	30	11	90	231,5	175	3,3	F-07	70	4×9			
65	2 1/2"	8	135	82	46	108	30	11	90	247	175	4,0	F-07	70	4×9			
80	3"	8	141	91	46	124	30	11	90	262	194	4,8	F-07	70	4×9			
80	3"	4	141	75	46	124	30	11	90	246	185	3,6	F-07	70	4×9			
100	4"	8	165	105	52	147,3	30	11	90	300	224	6,4	F-07	70	4×9			
125	5"	8	180	125	56	180	33	14	90	338	267	9,9	F-07	70	4×9			
150	6"	8	193	136,5	56	206,5	33	14	90	362,5	292	10,6	F-07	70	4×9			
200	8"	8	225	156	60	257	33	17	90	414	334	13,5	F-07	70	4×9			
200	8"	12	225	171	60	257	33	17	90	429	352	17,5	F-07	70	4×9			
250	10"	12	282,5	210	68	324	23	22	130	515,5	409	26,5	F-10	102	4×12	3	70	
300	12"	12	308	240	78	383	23	22	130	571	480	39,6	F-10	102	4×12	3	70	
350	14"	16	338,5	263	78	437	31	22	160	632,5	522	56	F-10	102	4×12	3	70	
350	14"	12	338,5	263	78	437	31	22	160	632,5	522	55,4	F-10	102	4×12	3	70	
400	16"	16	380	308	102	486	31	27	160	719	595	74,8	F-12	125	4×14	4	85	
450	18"	20	380,5	340	114	538	38	36	190	758,5	633	101,4	F-14	140	4×18	4	100	
450	18"	16	380,5	340	114	538	38	36	190	758,5	633	94,4	F-14	140	4×18	4	100	
500	20"	20	432,5	380	127	613	38	36	210	850,5	717	154,4	F-14	140	4×18	4	100	
600	24"	20	494	440	154	690	80	60	210	1 014	833	215,9	F-16	165	4×22	5	130	
700	28"	24	590	490	165	832	106	65	300	1 186	904	287	F-25	254	8×18	5	200	
750	30"	24	590	530	190	836	106	80	300	1 226	964	370	F-25	254	8×18	5	200	
750	30"	28	590	530	190	836	106	80	300	1 226	979	391,4	F-25	254	8×18	5	200	
800	32"	24	630	565	190	902	106	80	300	1 301	1 020	425,5	F-25	254	8×18	5	200	
900	36"	28	695	610	203	1 010	110	80	350	1 415	1 120	530,5	F-25	254	8×18	5	200	
1 000	40"	28	770	675	216	1 116	110	80	350	1 555	1 246	680,7	F-25	254	8×18	5	200	

ROZMĚRY S OVLÁDÁNÍM / DIMENSIONS WITH OPERATING

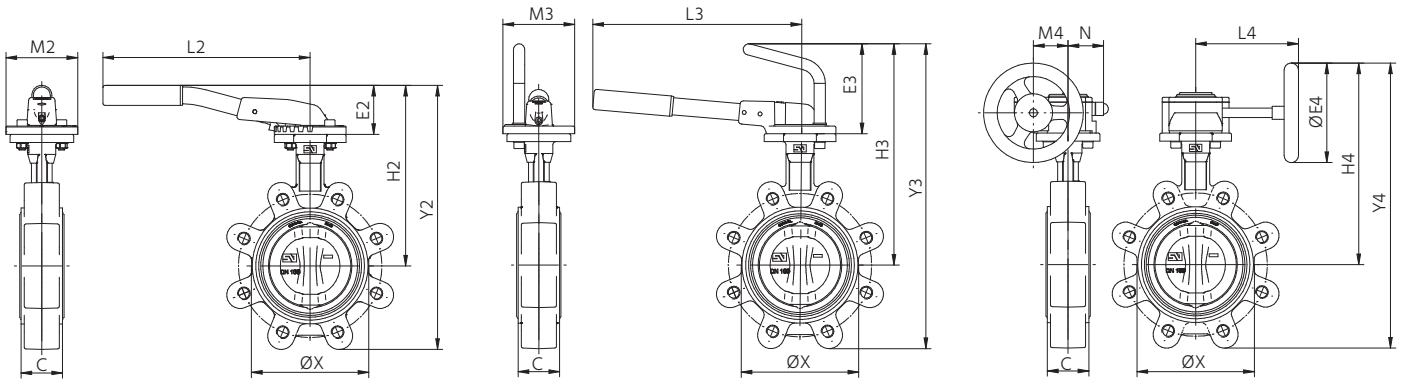

MN - ruční páka (zarážky po 15°)
MN - handlever (notch every po 15°)

MR - páka s vačkou
MR - handlever with blocking in all positions

MDV - převod s ručním kolem
MDV - gearbox with handwheel

DN		MN								MR								MDV							
mm	Inch	C	X	E2	H2	Y2	L2	M2	Kg	E3	H3	Y3	L3	M3	Kg	REF	E4	H4	Y4	L4	M4	N	Kg		
25	1"	33	68	49	151,5	202	220	90	2,2	113	215,5	266	260	90	2,5	0	125	190,5	241	129	43,5	50,5	3,1		
32	1 1/4"	33	68	49	151,5	202	220	90	2,2	113	215,5	266	260	90	2,5	0	125	190,5	241	129	43,5	50,5	3,1		
40	1 1/2"	33	76	49	159	213	220	90	2,4	113	223	277	260	90	2,7	0	125	198	252	129	43,5	50,5	3,2		
50	2"	43	100	49	169	228,5	220	90	3,3	113	233	292,5	260	90	3,6	0	125	208	267,5	129	43,5	50,5	4,1		
65	2 1/2"	46	108	49	184	250	220	90	3,7	113	248	314,5	260	90	3,9	0	125	223	289,5	129	43,5	50,5	4,5		
80	3"	46	124	60	201	292	260	90	5,2	113	254	345	260	90	5,4	0	125	229	320	129	43,5	50,5	6,0		
100	4"	52	147,3	60	225	330	260	90	6,9	113	278	383	260	90	7,1	0	125	253	358	129	43,5	50,5	7,6		
125	5"	56	180	75	255	380	315	90	10,5	113	293	418	310	90	10,6	1	160	285,5	410,5	135	43,5	50,5	11,3		
150	6"	56	206,5	75	268	404	315	90	11,2	113	306	442,5	310	90	11,3	1	160	298,5	435	135	43,5	50,5	12,0		
200	8"	60	257	75	300	456	315	90	14,1	113	338	494	310	90	14,2	1A	200	355	527,5	152	52,5	59	16,1		
250	10"	68	324							121	403,5	613,5	500	130	28,3	2	250	442,5	652,5	222	61,2	70,5	30,1		
300	12"	78	383							121	429	669	500	130	41,3	2	250	468	708	222	61,2	70,5	43,1		
350	14"	78	437							121	459,5	722,5	500	130	57,7	2	250	498,5	761,5	222	61,2	70,5	59,5		
400	16"	102	486													2A	300	572,5	880,5	278	68,8	72,5	83,7		
450	18"	114	538													3	400	630,5	970,5	321	96,5	91,5	120		
500	20"	127	613													3	400	682,5	1063	321	96,5	91,5	173		
600	24"	154	690													4	500	798,5	1239	408	137,5	140	250		
700	28"	165	832													4	600	944,5	1435	424	137,5	140	322		
750	30"	190	836													5	600	944,5	1475	456	137,5	140	411		
800	32"	190	902													5	600	984,5	1550	456	137,5	140	466		
900	36"	203	1010													6	700	1109	1719	510	180	156	591		
1000	40"	216	1116													7	700	1184	1859	579	180	156	747		

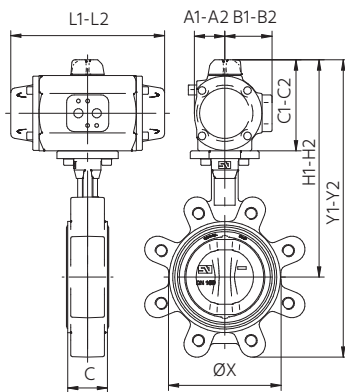

MND - 2-činný pneumatický pohon / double acting pneumatic actuator
MNS - 1-činný pneumatický pohon / spring return pneumatic actuator

DN		2-ČINNÝ / DOUBLE ACTING										1-ČINNÝ / SPRING RETURN								
mm	Inch	C	X	REF	A1	B1	C1	H1	Y1	L1	Kg1	REF	A2	B2	C2	H2	Y2	L2	Kg2	
25	1"	33	68	PA00	31,9	52,2	120,5	223	273,3	152,8	3,3	PA00S	31,9	52,2	120,5	223	273,3	152,8	3,5	
32	1 1/4"	33	68	PA00	31,9	52,2	120,5	223	273,3	152,8	3,3	PA00S	31,9	52,2	120,5	223	273,3	152,8	3,5	
40	1 1/2"	33	76	PA00	31,9	52,2	120,5	230,5	284,5	152,8	3,4	PA00S	31,9	52,2	120,5	230,5	284,5	152,8	3,6	
50	2"	43	100	PA00	31,9	52,2	120,5	240,5	300	152,8	4,3	PA00S	31,9	52,2	120,5	240,5	300	152,8	4,5	
65	2 1/2"	46	108	PA05	39,9	61,7	119	254	320,5	201,2	5,9	PA05S	39,9	61,7	119	254	320,5	201,2	6,2	
80	3"	46	124	PA05	39,9	61,7	119	260	351	201,2	7,4	PA10S	40,9	62,7	123	264	355	225	8,3	
100	4"	52	147,3	PA05	39,9	61,7	119	284	389	201,2	9,0	PA15S	48,9	70,5	138,6	303,6	408,5	265	11,4	
125	5"	56	180	PA10	40,9	62,7	123	303	429,5	428	13,0	PA20S	52,4	75,1	146,8	326,8	451,8	310	16,5	
150	6"	56	206,5	PA15	48,9	70,5	138,6	331,6	468	265	14,8	PA25S	64,3	89,2	174,8	367,8	504,2	358,2	21,9	
200	8"	60	257	PA20	52,3	75,1	146,8	371,8	527,7	310	19,1	PA30S	71,7	97,3	191,3	416,3	572,3	427,5	28,8	
250	10"	68	324	PA25	64,2	89,2	174,8	457,2	667,2	358,2	35,9	P40S	106	120	272	554,5	764,5	598	63,0	
300	12"	78	383	PA30	71,7	97,3	191,3	499,3	739,3	427,5	51,2	P40S	106	120	272	580	820	598	76,0	
350	14"	78	430	P40	106	120	272	610,5	873,5	444	73,6	P40S	106	120	272	610,5	873,5	598	92,4	
400	16"	102	486	P40	106	120	272	652	960	444	92,4	P50S	122,5	135	383	763	1071	694	135	
450	18"	114	538	P50	122,5	135	313	693,5	1033	524	132	PA60S	158,5	172	438	818,5	1158	672,5	186	
500	20"	127	613	P50	122,5	135	313	745,5	1125	524	185	PA70S	186	217	498	930,5	1310	742,5	273	
600	24"	154	690	PA60	158,5	172	368	862	1302	672,5	264									
700	28"	165	832	PA70	186	217	453	1043	1533	742,5	376									
750	30"	190	836																	
800	32"	190	902																	

MOŽNOSTI MONTÁŽE MEZI PŘÍRUBY / POSSIBILITIES OF ASSEMBLY BETWEEN FLANGES

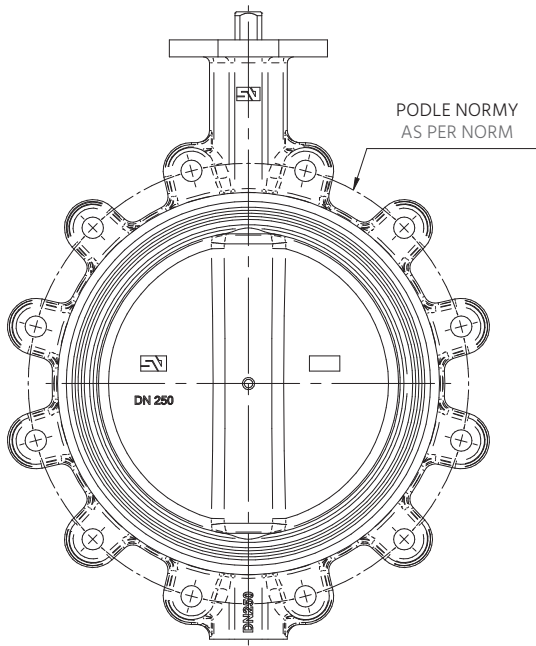

DN	25	32	40	50	65	80	100	125	150	200	250	300	350	400	450	500	600	700	750	800	900	1000	
PN.6	X	X	X	X	X	X	O	X	X	X	X	X	X	X	X	O	O	-	X	O	-	O	
PN.10	X	X	X	X	X	X	X	X	X	X	X	X	X	X	X	X	X	X	X	X	X	X	X
PN.16	X	X	X	X	X	X	X	X	X	X	X	X	X	X	X	X	X	X	X	X	X	X	X
PN.20	X	X	X	X	X	X	X	X	X	X	X	X	X	X	X	X	X	X	X	X	X	X	X
ANSI 150 Lbs AWWA	X	X	X	X	X	X	X	X	X	X	X	X	X	X	X	X	X	-	X	-	-	-	
ASME B16.47a-150																		-	X	-	-	-	
ASME B16.47a-300																		-	-	-	-	-	
ASME B16.47b-150																		-	-	-	-	-	
ASME B16.47b-300																		-	-	-	-	-	
BS, D	X	X	X	X	X	X	O	X	X	X	O	X	X	O	O	O	O						
BS, E	X	X	X	X	X	X	X	X	X	X	X	X	X	O	X	O	O						
JIS 5k	X	X	X	-	X	X	X	X	X	X	X	X	O	X	X	O	X	X	X	X	O	-	O
JIS 10k	X	X	X	X	X	X	X	X	X	X	X	O	X	X	X	X	O	X	X	X	-	X	X
JIS 16k	X	X	X	O	O	X	X	X	X	O	O	O	X	X	O	X	O	-	-	-	-	-	
AS 2129 E	X	X	X	X	X	X	X	X	X	X	X	X	X	O	X	O	O	-	-	-	-	-	

X STANDARDNÍ / STANDARD
 O NA VYŽÁDÁNÍ / ON REQUEST
 - NENÍ MOŽNÉ / NOT POSSIBLE

MONTÁŽ MEZI PŘÍRUBY / ASSEMBLY BETWEEN FLANGES

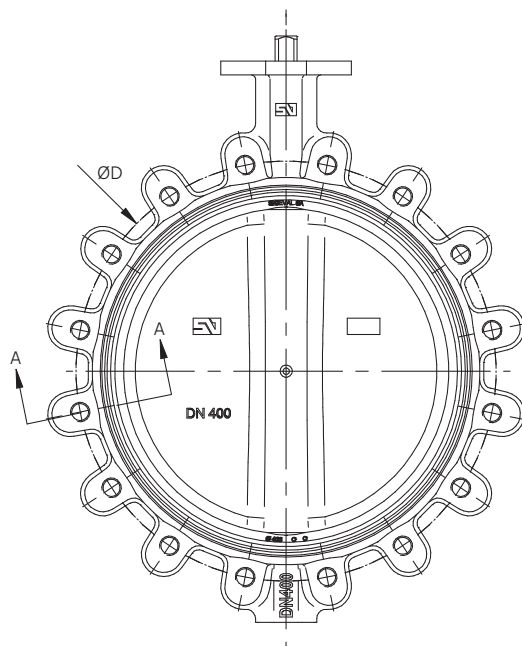
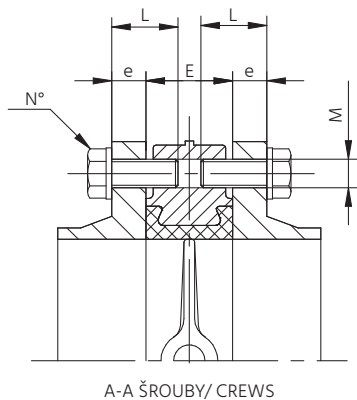

Závitové otvory pro montáž mezi příruby se závity:

- metrickými (PN 10/16)
- UNC (ANSI 150)
- ostatní typy na přání

Threaded holes for the assembly between flanges will be:

- metric thread standards for pn. norms:
- UNC thread standards for ANSI 150 norms
- other thread on request

DN	E	PN10					PN16					ANSI 150 Lbs				
		D	e	M	L	N°	D	e	M	L	N°	D	e	M	L	N°
25	33	85	16	M12	30	8	85	16	M12	30	8	79,4	14,3	1/2"	30	8
32	33	100	16	M16	30	8	100	16	M16	30	8	88,9	17,5	1/2"	30	8
40	33	110	16	M16	30	8	110	16	M16	30	8	98,4	17,5	1/2"	30	8
50	43	125	18	M16	35	8	125	18	M16	35	8	120,6	19	5/8"	35	8
65	46	145	18	M16	40	8	145	18	M16	40	8	139,7	22,2	5/8"	45	8
80	46	160	20	M16	40	16	160	20	M16	40	16	152,4	23,8	5/8"	45	8
100	52	180	20	M16	45	16	180	20	M16	45	16	190,5	23,8	5/8"	45	16
125	56	210	22	M16	50	16	210	22	M16	50	16	215,9	23,8	3/4"	50	16
150	56	240	22	M20	50	16	240	22	M20	50	16	241,3	25,4	3/4"	50	16
200	60	295	24	M20	50	16	295	24	M20	50	24	298,5	28,6	3/4"	55	16
250	68	350	26	M20	60	24	355	26	M24	60	24	361,9	30,2	7/8"	60	24
300	78	400	26	M20	65	24	410	28	M24	65	24	431,8	31,7	7/8"	70	24
350	78	460	26	M20	65	32	470	30	M24	65	32	476,2	34,9	1"	70	24
400	102	515	26	M24	75	32	525	32	M27	80	32	539,7	36,5	1"	85	32
450	114	565	26	M24	75	32	585	32	M27	80	32	577,8	39,5	1 1/8"	85	32
				M24	60	8			M27	60	8					
500	127	620	28	M24	90	40	650	34	M30	65	40	635,0	46	1 1/8"	105	40
600	154	725	28	M27	100	40	770	36	M33	110	40	749,3	47,6	1 1/4"	120	40
700	165	840	30	M27	110	40	840	36	M33	120	40					
				M27	80	8			M33	85	8					
750	190	900	32	M30	130	40	900	38	M33	130	40	914,4	54	1 1/4"	150	48
				M30	100	8			M33	100	8					
800	190	950	32	M30	130	40	950	38	M36	130	40					
				M30	110	8			M36	110	8					
900	203	1050	34	M30	130	48	1050	40	M36	140	48					
				M30	95	8			M36	100	8					
1000	216	1160	34	M33	140	48	1170	42	M39	150	48					
				M33	95	8			M39	100	8					

UZAVÍRACÍ KLAPKY TYP FG(W) / VALVES TYPE FG(W)



Typ tělesa / Body type	přírubové / FLANGED
Rozsah DN / Production Range	DN 150–1 600
Konstrukce / Standard Design	EN 593
Stavební délka / Face to Face	EN 558-1 řada / serie 20 (DIN 3202 T3 K1) ISO 5752 T5 krátká / short type API 609, BS 5155 řady / series 4–5, vyjma / except DN350
Vrchní příruba / Top Flange	EN ISO 5211 / NFE 29-402
Vrtání přírub / Drilling Norm	DIN PN 10/16, ANSI cl. 150
Norma označení / Marking	EN 19
Max. pracovní tlak Max. working pressure	16 bar DN 150 10 bar DN 200–1 600 (16 bar pouze do / to only DN 1200–na přání / on request)
Pracovní teplota / Working temperature	-40 °C + 210 °C
Zkoušky armatur/ Hydraulic tests	EN 12266 / ISO 5208

Uzavírací klapky přírubové typ FG(w) mají jednoduché robustní těleso s přírubami vrtanými dle různých norem (DIN, ANSI, BS, etc.). Konstrukce klapky umožňuje montáž na konec potrubí. V takovém případě je max. povolený pracovní tlak $0,4 \times PN$. Provozovat klapku na konci potrubí na plný tlak je možné pouze tehdy, pokud je zpevněná protipřírubou. Tyto klapky se používají především ve vodních elektrárnách, čistírnách a úpravnách vody, čerpacích stanicích a filtračních systémech.

The FG(w) double flanged type is a one piece body design with flanges to suit all standards (DIN, ANSI, BS, etc.). The design of the valve allows its installation at the end of the pipeline. In this case, the maximum working pressure is $0.4 \times PN$. Butterfly valve under full pressure at the end of pipeline is possible to keep if it is reinforced with a counter-flange only. It is used in water power plants, water treatment plants, pump stations or filtration systems especially.

Oblasti použití / Applications



- Filtrace
- Čištění a úprava vody
- Rozvody vody
- Chladicí systémy
- Lodní průmysl

- Filtration
- Water treatment
- Water distribution
- Cooling systems
- Shipbuilding

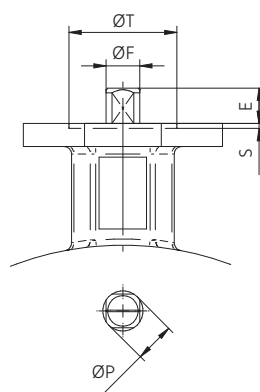
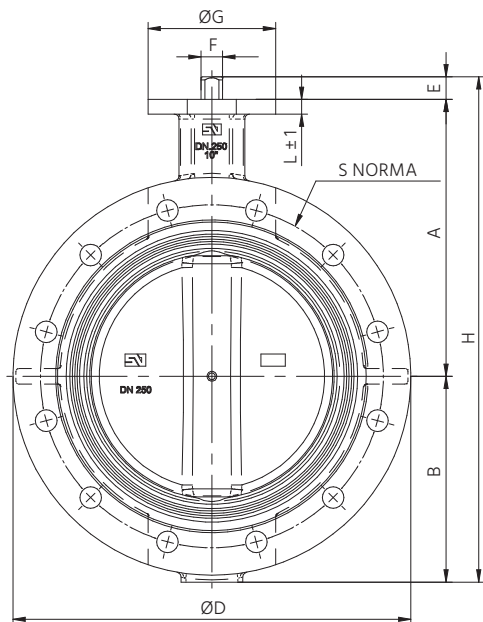

DN150/500

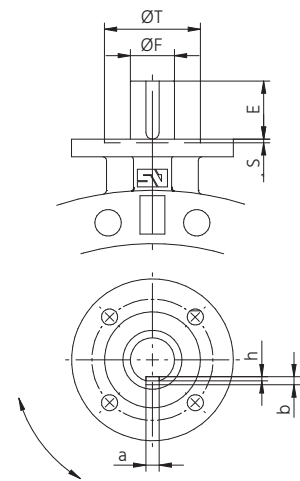

DN600/1600

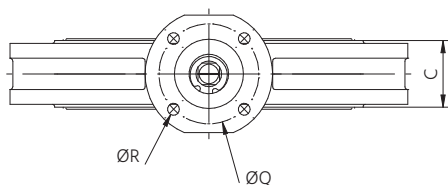

DN		ZÁKLADNÍ ROZMĚRY / GENERAL DIMENSIONS									VRCHNÍ PŘÍRUBA / TOP FLANGE				
mm	inch	A	B	C	D	E	F	G	H	Kg	ISO	Q	R	S	T
150	6"	193	143	56	285	33	14	90	369	11,0	F-07	70	4×9		
200	8"	225	172,5	60	345	33	17	90	430,5	18,4	F-07	70	4×9		
250	10"	282,5	210	68	406	23	22	130	515,5	30,8	F-10	102	4×12	3	70
300	12"	308	240	78	480	23	22	130	571	45,4	F-10	102	4×12	3	70
350	14"	338,5	268	78	535	31	22	160	637,5	54,4	F-10	102	4×12	3	70
400	16"	380	308	102	597	31	27	160	719	79,2	F-12	125	4×14	4	85
450	18"	380,5	340	114	640	38	36	190	758,5	106,9	F-14	140	4×18	4	100
500	20"	432,5	380	127	700	38	36	210	850,5	134,5	F-14	140	4×18	4	100
600	24"	494	440	154	834	80	60	210	1 014	223,9	F-16	165	4×22	5	130
700	28"	590	490	165	910	106	65	300	1 186	278,4	F-25	254	8×18	5	200
750	30"	590	530	190	995	106	80	300	1 226	373,5	F-25	254	8×18	5	200
800	32"	630	565	190	1 060	106	80	300	1 301	412,5	F-25	254	8×18	5	200
900	36"	695	610	203	1 170	110	80	350	1 415	528	F-25	254	8×18	5	200
1 000	40"	770	675	216	1 290	110	80	350	1 555	704,7	F-25	254	8×18	5	200
1 100	44"	815	733	216	1 405	110	80	350	1 658	877,1	F-25	254	8×18	5	200
1 200	48"	875	818	254	1 485	110	100	350	1 803	1 094	F-30	298	8×23	5	230
1 400	56"	1 000	969	280	1 735	120	120	350	2 089	1 656	F-30	298	8×23	5	230
1 500	60"	1 075	1 050	318	1 855	160	130	475	2 285	2 009	F-40	406	8×39	8	300
1 600	64"	1 115	1 090	318	1 930	160	130	475	2 365	2 132	F-40	406	8×39	8	300

ROZMĚRY S OVLÁDÁNÍM / DIMENSIONS WITH OPERATING

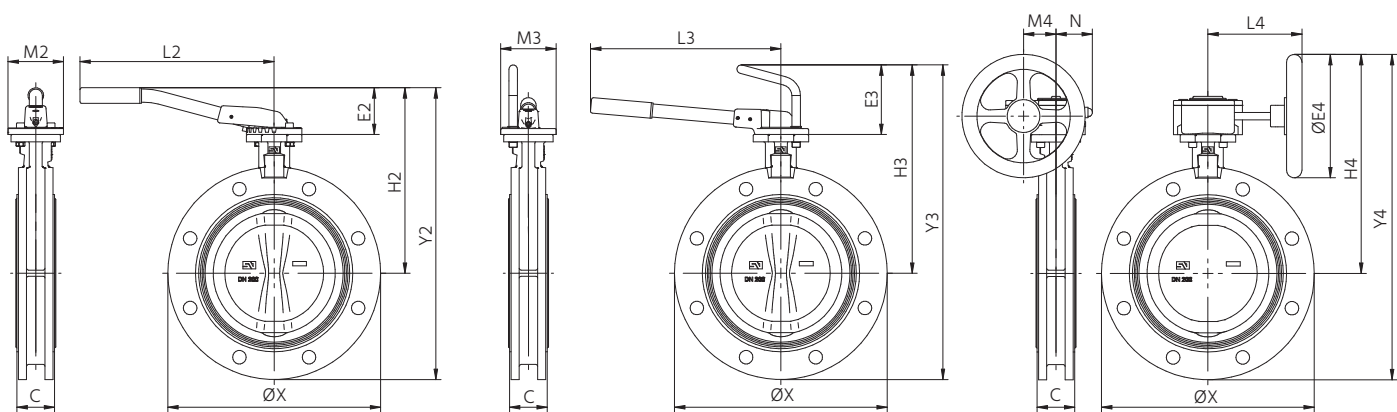

MN - ruční páka (zarážky po 15°)
MN - handlever (notch every 15°)

MR - páka s vačkou
MR - handlever with blocking in all positions

MDV - převod s ručním kolem
MDV - gearbox with handwheel

DN		MN									MR						MDV						
Mn	Inch	C	X	E2	H2	Y2	L2	M2	Kg	E3	H3	Y3	L3	M3	Kg	REF	E4	H4	Y4	L4	M4	N	Kg
150	6"	56	285	75	268	411	315	90	11,5	113	306	448	310	90	11,7	1	160	298,5	441	135	43,5	50,5	12,4
200	8"	60	345	75	300	472	315	90	18,9	113	338	510	310	90	19,1	1A	200	355	527	152	52,5	59	21,0
250	10"	68	406							121	403,5	613,5	500	130	32,5	2	250	442,5	652,5	222	61,2	70,5	34,3
300	12"	78	480							121	429	669	500	130	47,1	2	250	468	708	222	61,2	70,5	48,9
350	14"	78	535							121	459,5	727,5	500	130	56,1	2	250	498,5	766,5	222	61,2	70,5	57,9
400	16"	102	597													2A	300	572,5	880,5	278	68,8	72,5	88,1
450	18"	114	640													3	400	630,5	970,5	321	96,5	91,5	118
500	20"	127	700													3	400	682,5	1063	321	96,5	91,5	153
600	24"	154	834													4	500	798,5	1239	408	137,5	140	251
700	28"	165	916													4	600	944,5	1435	424	137,5	140	309
750	30"	190	995													5	600	944,5	1475	456	137,5	140	390
800	32"	190	1060													5	600	984,5	1550	456	137,5	140	436
900	36"	203	1170													6	700	1109	1719	510	180	156	572
1000	40"	216	1290													7	700	1184	1859	579	180	156	771
1100	44	216	1405													7	700	1229	1962	579	180	156	925
1200	48	254	1485													8	700	1310	2128	593	252,5	228	1290
1400	56	280	1735													8	700	1435	2404	593	252,5	228	1852
1500	60	318	1855													9	700	1510	2560	593	252,5	228	2205
1600	64	318	1930													9	700	1550	2640	593	252,5	228	2328

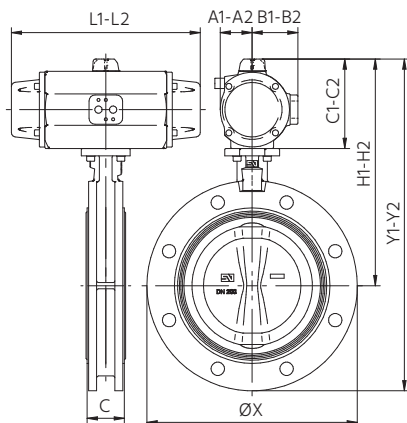

MND - 2-činný pneumatický pohon / double acting pneumatic actuator

MNS - 1-činný pneumatický pohon / spring return pneumatic actuator

DN		2-ČINNÝ / DOUBLE ACTING										1-ČINNÝ / SPRING RETURN								
Mn	Inch	C	X	REF	A1	B1	C1	H1	Y1	L1	Kg1	REF	A2	B2	C2	H2	Y2	L2	Kg2	
150	6"	56	285	PA15	48,9	70,5	138,6	331,6	474	265	15,2	PA25S	64,3	89,2	174,8	367,8	510,2	358,2	22,3	
200	8"	60	345	PA20	52,3	75,1	146,8	371,8	544,2	310	24,0	PA30S	71,7	97,3	191,3	416,3	588,8	427,5	33,7	
250	10"	68	406	PA25	64,2	89,2	174,8	457,2	667,2	358,2	40,1	P40S	106	120	272	554,5	764,5	598	67,2	
300	12"	78	480	PA30	71,7	97,3	191,3	499,3	739,3	427,5	57,0	P40S	106	120	272	580	820	598	81,8	
350	14"	78	535	P40	106	120	272	610,5	878,8	444	72,0	P40S	106	120	272	610,5	878,5	598	90,8	
400	16"	102	597	P40	106	120	272	652	960	444	96,8	P50S	122,5	135	383	763	1071	694	139	
450	18"	114	640	P50	122,5	135	313	693,5	1033	524	131	PA60S	158,5	172	438	818,5	1158	672,5	185	
500	20"	127	700	P50	122,5	135	313	745,5	1125	524	165	PA70S	186	217	498	930,5	1310	742,5	253	
600	24"	154	834	PA60	158,5	172	368	862	1302	672,5	265									
700	28"	165	916	PA70	186	217	453	1043	1533	742,5	363									
750	30"	190	995																	
800	32"	190	1060																	

MOŽNOSTI MONTÁŽE MEZI PŘÍRUBY / POSSIBILITIES OF ASSEMBLY BETWEEN FLANGES

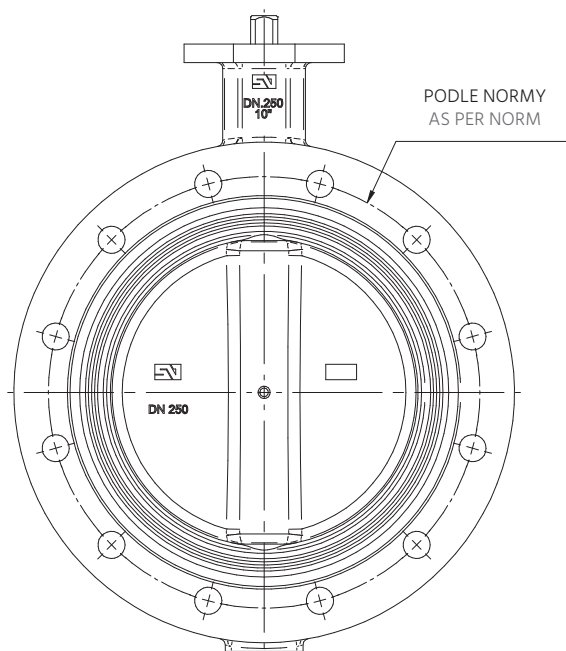

DN	150	200	250	300	350	400	450	500	600	700	750	800	900	1000	1100	1200	1400	1500	1600
PN.6	X	X	X	X	O	O	O	O	O	-	X	O	O	O	X	O	X	O	X
PN.10	X	X	X	X	X	X	X	X	X	X	X	X	X	X	X	X	X	X	X
PN.16	X	X	X	X	X	X	X	X	X	X	X	X	X	X	X	X	X	X	X
PN.20	X	X	X	X	X	X	X	X	X										
ANSI 150 Lbs	X	X	X	X	X	X	X	X	X	X	X	X	X	X	X	X	X	X	
AWWA	X	X	X	X	X	X	X	X	X	X	X	X	X	X	X	X	X	X	
ASME B16.47a-150										X	X	X	X	X	X	X	X	X	
ASME B16.47a-300										-	-	-	-	O	X	X	O	X	
ASME B16.47b-150										-	O	O	O	O	O	O	O	O	
ASME B16.47b-300										O	X	X	X	X	X	O	X	X	
BS, D	X	X	X	X	X	X	X	X	X		X		X			X			
BS, E	X	X	X	X	X	X	X	X	X		X		X			X			
JIS 5k	X	X	X	O	O	O	O	X	X	O	X	X	O	O	X	O			
JIS 10k	X	X	X	X	O	X	X	X	X	X	X	X	X	X	X	X			
JIS 16k	-	X	-	X	X	X	X	X	X	-	X	X	X	X	X	X			
AS 2129 E	X	X	X	X	X	X	X	X	X	O	X	X	X	X		X			

X STANDARDNÍ / STANDARD
 O NA VYŽÁDÁNÍ / ON REQUEST
 - NENÍ MOŽNÉ / NOT POSSIBLE

MONTÁŽ MEZI PŘÍRUBY / ASSEMBLY BETWEEN FLANGES

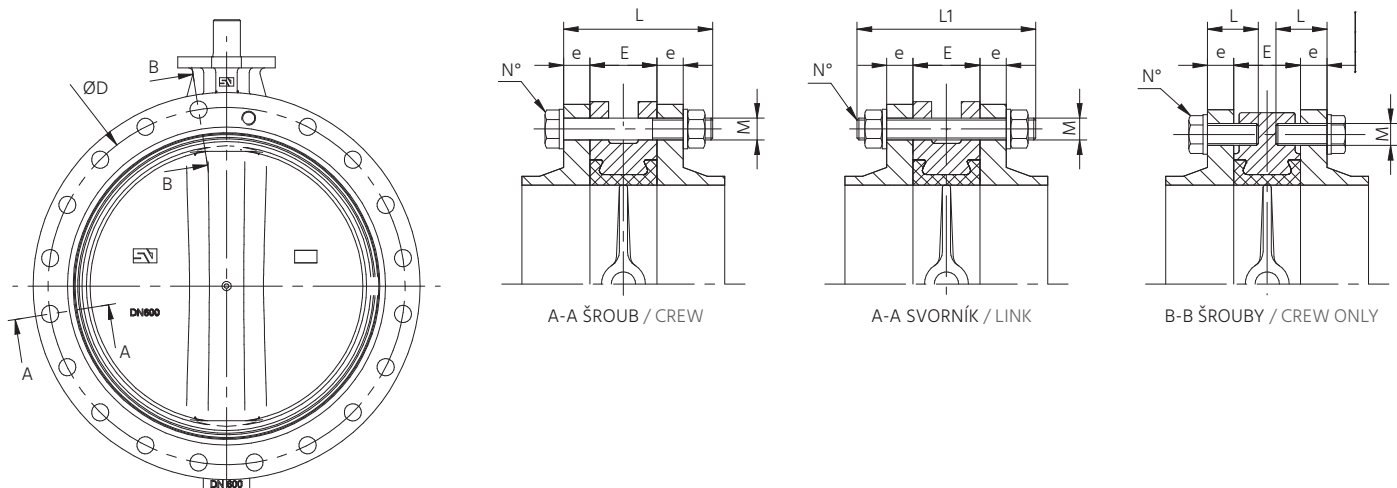

Závitové otvory pro montáž mezi přírubby se závitují:

- metrickými (PN 10/16)
- UNC (ANSI 150)
- ostatní typy na přání

Threaded holes for the assembly between flanges will be:

- metric thread standards for pn. norms
- UNC thread standards for ANSI 150 norms
- other thread on request

DN	E	PN10						PN16						ANSI 150 Lbs					
		D	e	M	L	L1	N°	D	e	M	L	L1	N°	D	e	M	L	L1	N°
150	56	240	22	M20	130	150	8	240	22	M20	130	150	8	241,3	25,4	3/4"	130	150	8
200	60	295	24	M20	130	160	8	295	24	M20	130	160	12	298,5	28,6	3/4"	140	160	8
250	68	350	26	M20	150	170	12	355	26	M24	150	170	12	361,9	30,2	7/8"	160	180	12
300	78	400	26	M20	160	180	12	410	28	M24	160	180	12	431,8	31,7	7/8"	170	190	12
350	78	460	26	M20	170	180	16	470	30	M24	170	190	16	476,2	34,9	1"	180	200	12
400	102	515	26	M24	180	210	16	525	32	M27	200	220	16	539,7	36,5	1"	210	230	16
450	114	565	26	M24	190	220	16	585	32	M27	210	240	16	577,8	39,7	1 1/8"	230	250	16
				M24	60		8			M27	60		8						
500	127	620	28	M24	210	230	20	650	34	M30	230	260	20	635,0	46	1 1/8"	250	280	20
																1 1/8"	105		8
600	154	725	28	M27	240	270	20	770	36	M33	260	290	20	749,3	47,6	1 1/4"	280	310	20
700	165	840	30	M27	260	280	20	840	36	M33	270	300	20	863,5	52,5	1 1/4"	310	340	24
				M27	80		8			M33	85		8			1 1/4"	110		8
750	190	900	32	M30	290	320	20	900	38	M33	300	340	20	914,4	54	1 1/4"	335	375	24
				M30	95		8			M33	100		8			1 1/4"	110		8
800	190	950	32	M30	290	320	20	950	38	M36	310	345	20	978	57	1 1/2"	340	380	24
				M30	210		8			M36	80		8			1 1/2"	95		8
900	203	1050	34	M30	310	350	24	1050	40	M36	330	375	24	1086	60	1 1/2"	370	415	28
				M30	100		8			M36	100		8			1 1/2"	110		8
1000	216	1160	34	M33	325	360	24	1170	42	M39	345	390	24	1200	63,5	1 1/2"	390	430	32
				M33	95		8			M39	100		8			1 1/2"	120		8
1100	216	1270	38	M33	330	37	28	1270	48	M39	360	400	28	1314,5	101	1 1/2"	465	410	36
				M33	100		8			M39	110		8			1 1/2"	150		8
1200	254	1380	38	M36	375	420	28	1390	48	M45	395	445	28	1422	108	1 1/2"	475	520	40
				M36	110		8			M45	115		8			1 1/2"	165		8
1400	280	1590	42	M39	410	450	32	1590	52	M45	440	490	32	1651	124	1 3/4"	580	630	44
				M39	100		8			M45	110		8			1 3/4"	160		8
1500	318	1700	48	M39	460	505	32	1710	54	M52	490	550	32	1759	132	1 3/4"	635	690	44
				M39	110		8			M52	110		8			1 3/4"	190		16
1600	318	1820	46	M45	460	510	36	1820	58	M52	490	550	36						
				M45	100		8			M52	120		8						

UZAVÍRACÍ KLAPKY TYP KL / VALVES TYPE KL



Typ tělesa / Body type	bezpřírubové hliníkové / WAFER Aluminium
Rozsah DN / Production Range	DN 50–500
Konstrukce / Standard Design	EN 593
Stavební délka / Face to Face	EN 558-1 řada / serie 20 (DIN 3202 T3 K1) ISO 5752 T5 krátká / short type API 609, BS 5155 řady / series 4-5, vyjma / except DN350
Vrchní příruba / Top Flange	EN ISO 5211 / NFE 29-402
Vrtání přírub / Drilling Norm	DIN PN 6/10/16, ANSI cl. 150
Norma označení / Marking	EN 19
Max. pracovní tlak Max. working pressure	10 bar DN 50–100 6 bar DN 150 3 bar DN 200–500
Pracovní teplota / Working temperature	Max. 95 °C
Zkoušky armatur / Hydraulic tests	EN 12266 / ISO 5208

U tohoto typu uzavírací klapky výrobce využil spojení svých zkušeností za více než 25 let vývoje a výroby uzavíracích kapek a nejmodernějších technologií. Typ KL je požitelný pro celou oblast vytápění a klimatizace, tj. jak do rozvodů studené a teplé vody, tak studeného a teplého vzduchu. Tento typ klapky lze použít pro montáž mezi příruba s různými druhy norem vrtání a tam, kde je vyžadována nízká hmotnost a cena, např. rozvody vzduchu a neagresivních plynů nebo rozvody vody a jiných médií v zemědělsko-potravinářském průmyslu.

Manufacturer has developed this type of valve using the experience of more than 25 years in the design and production of butterfly valves together with use the latest technology. The KL type butterfly valve covers all the HVAC field: cold and hot water, air conditioning, etc. with common detachable and interchangeable components. The valve offers reduced weight and is suitable for the most common drilling norms of this market. This valve is suitable for applications where a light and economically priced valve is necessary: installations of air and non-corrosive gases, agricultural irrigation, agriculture-food industry, etc.

Oblasti použití / Applications

- Vytápění, větrání, klimatizace
- Rozvody vzduchu nebo plynu
- Zavlažování
- Potravinářský průmysl

- HVAC (Heat Ventilation Air Conditioning)
- Air or gas Instalations
- Irrigation systems
- Food industry



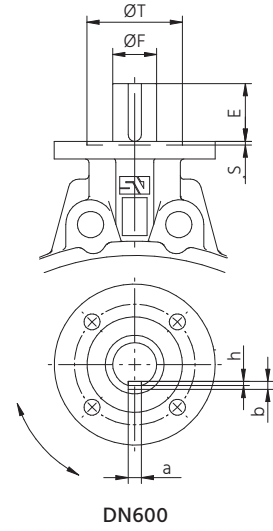
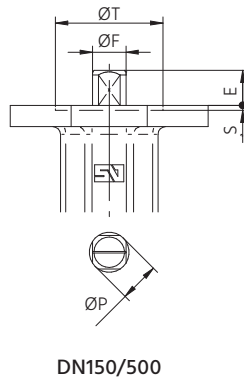
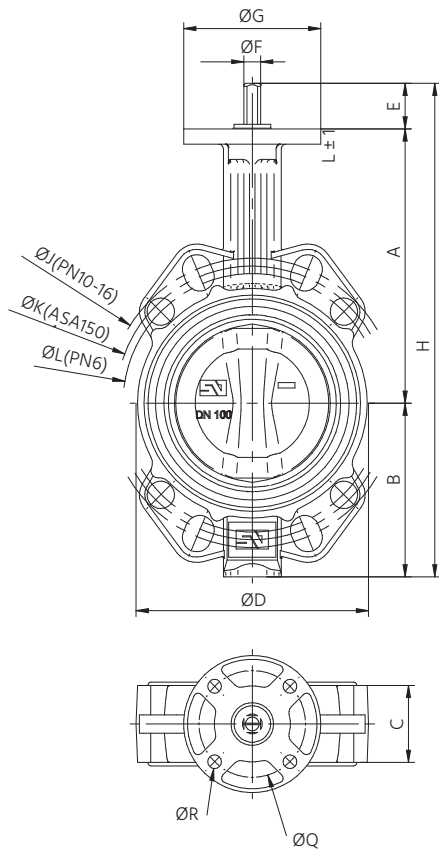

DN150/500

DN600

DN		ZÁKLADNÍ ROZMĚRY / GENERAL DIMENSIONS												VRCHNÍ PŘÍRUBA / TOP FLANGE				
mm	inch	A	B	C	D	E	F	G	H	J	K	L	Kg	ISO	Q	R	S	T
50	2"	140	80	43	96,5	30	11	90	250	125	120,7	110	1,2	F-07	70	4×9		
65	2 1/2"	154	91	46	112,5	30	11	90	275	145	139,7	130	1,6	F-07	70	4×9		
80	3"	160	100	46	127,5	30	11	90	290	160	152,4	150	1,9	F-07	70	4×9		
100	4"	180	114	52	152,5	30	11	90	324	180	190,5	170	2,3	F-07	70	4×9		
125	5"	197	130	56	180	33	14	90	360	210	215,9	200	3,4	F-07	70	4×9		
150	6"	210	144,5	56	207	33	14	90	287,5	240	241,3	225	4,3	F-07	70	4×9		
200	8"	240	175	60	265	33	17	90	448	295	298,5	280	7,3	F-07	70	4×9		
250	10"	282,5	210	68	324	23	22	130	515,5	362	335		12,1	F-10	102	4×12	3	70
300	12"	308	240	78	376	23	22	130	571	431,8	394		18,1	F-10	102	4×12	3	70
350	14"	338,5	263	78	430	31	22	160	632,5	476,3	445		23,0	F-10	102	4×12	3	70
400	16"	380	308	102	485	31	27	160	719	540	510		26,1	F-12	125	4×14	4	85
450	18"	380,5	340	114	536	38	36	190	758,5				54,6	F-14	140	4×18	4	100
500	20"	432,5	380	127	593	38	36	210	850,5				72,9	F-14	140	4×18	4	100

ROZMĚRY S OVLÁDÁNÍM / DIMENSIONS WITH OPERATING

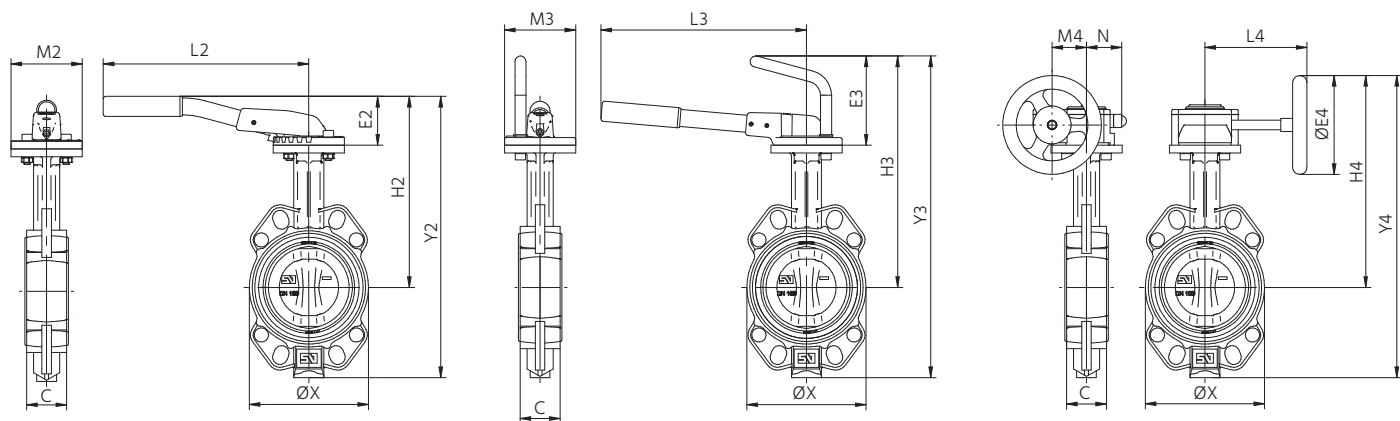

MN - ruční páka (zarážky po 15°)
MN - handlever (notch every po 15°)

MR - páka s vačkou
MR - handlever with blocking in all positions

MDV - převod s ručním kolem
MDV - gearbox with handwheel

DN		MN									MR						MDV						
Mn	Inch	C	X	E2	H2	Y2	L2	M2	Kg	E3	H3	Y3	L3	M3	Kg	REF	E4	H4	Y4	L4	M4	N	Kg
50	2"	43	96,5	49	189	269	220	90	1,6	113	253	333	260	90	1,8	0	125	228	308	129	43,5	50,5	2,4
65	2 1/2"	46	112,5	49	203	291	220	90	2,0	113	267	358	260	90	2,2	0	125	242	333	129	43,5	50,5	2,8
80	3"	46	127,5	60	220	320	260	90	2,3	113	273	373	260	90	2,5	0	125	248	348	129	43,5	50,5	3,1
100	4"	52	152,5	60	240	354	260	90	2,8	113	293	407	260	90	2,9	0	125	268	382	129	43,5	50,5	3,5
125	5"	56	180	75	272	402	315	90	3,9	113	310	440	310	90	4,1	1	160	302,5	432,5	135	43,5	50,5	4,8
150	6"	56	207	75	285	430	315	90	4,8	113	323	468	310	90	5,0	1	160	315,5	460	135	43,5	50,5	5,7
200	8"	60	265	75	315	490	315	90	7,9	113	353	528	310	90	8,0	1A	200	370	545	152	52,5	59	9,9
250	10"	68	324							121	403,5	613,5	500	130	13,8	2	250	442,5	652,5	222	61,2	70,5	15,6
300	12"	78	376							121	429	669	500	130	19,8	2	250	468	708	222	61,2	70,5	21,6
350	14"	78	430							121	459,5	722,5	500	130	24,7	2	250	498,5	761,5	222	61,2	70,5	26,5
400	16"	102	485													2A	300	572,5	880,5	278	68,8	72,5	45,0
450	18"	114	536													3	400	630,5	970,5	321	96,5	91,5	73,0
500	20"	127	593													3	400	682,5	1063	321	96,5	91,5	91,3
600	24"	154	690													4	500	798,5	1239	408	137,5	140	148

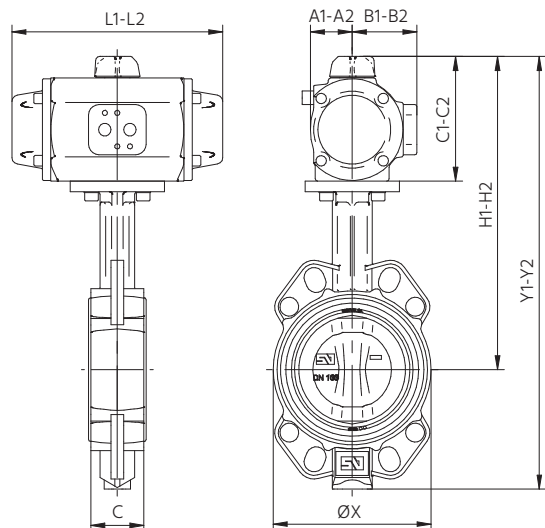

MND - 2-činný pneumatický pohon / double acting pneumatic actuator
MNS - 1-činný pneumatický pohon / spring return pneumatic actuator

DN		2-ČINNÝ / DOUBLE ACTING											1-ČINNÝ / SPRING RETURN						
Mn	Inch	C	X	REF	A1	B1	C1	H1	Y1	L1	Kg1	REF	A2	B2	C2	H2	Y2	L2	Kg2
50	2"	43	96,5	PA00	31,9	52,2	120,5	260,5	340,5	152,8	2,6	PA00S	31,9	52,2	120,5	260,5	340,5	152,8	2,8
65	2 1/2"	46	112,5	PA05	39,9	61,7	119	273	364	201,2	4,2	PA05S	39,9	61,7	119	273	364	201,2	4,5
80	3"	46	127,5	PA05	39,9	61,7	119	279	379	201,2	4,5	PA10S	40,9	62,7	123	283	383	225	5,4
100	4"	52	152,5	PA05	39,9	61,7	119	299	413	201,2	4,9	PA15S	48,9	70,5	138,6	318,6	432,6	265	7,7
125	5"	56	180	PA10	40,9	62,7	123	320	450	428	6,5	PA20S	52,4	75,1	146,8	343,8	473,8	310	10,0
150	6"	56	207	PA15	48,9	70,5	138,6	348,6	493,1	265	8,5	PA25S	64,3	89,2	174,8	384,8	529,3	358,2	15,6
200	8"	60	265	PA20	52,3	75,1	146,8	386,8	561,8	310	12,9	PA30S	71,7	97,3	191,3	431,3	606,3	427,5	22,6
250	10"	68	324	PA25	64,2	89,2	174,8	457,2	667,2	358,2	21,4	P40S	106	120	272	554,5	764,5	598	48,5
300	12"	78	383	PA30	71,7	97,3	191,3	499,3	739,3	427,5	29,7	P40S	106	120	272	580	820	598	54,5
350	14"	78	430	P40	106	120	272	610,5	873,5	444	40,6	P40S	106	120	272	610,5	873,5	598	59,4
400	16"	102	486	P40	106	120	272	652	960	444	53,7	P50S	122,5	135	383	763	1071	694	96,2
450	18"	114	538	P50	122,5	135	313	693,5	1033	524	85,3	PA60S	158,5	172	438	818,5	1158	672,5	140
500	20"	127	613	P50	122,5	135	313	745,5	1125	524	104	PA70S	186	217	498	930,5	1310	742,5	191

MOŽNOSTI MONTÁŽE MEZI PŘÍRUBY / POSSIBILITIES OF ASSEMBLY BETWEEN FLANGES

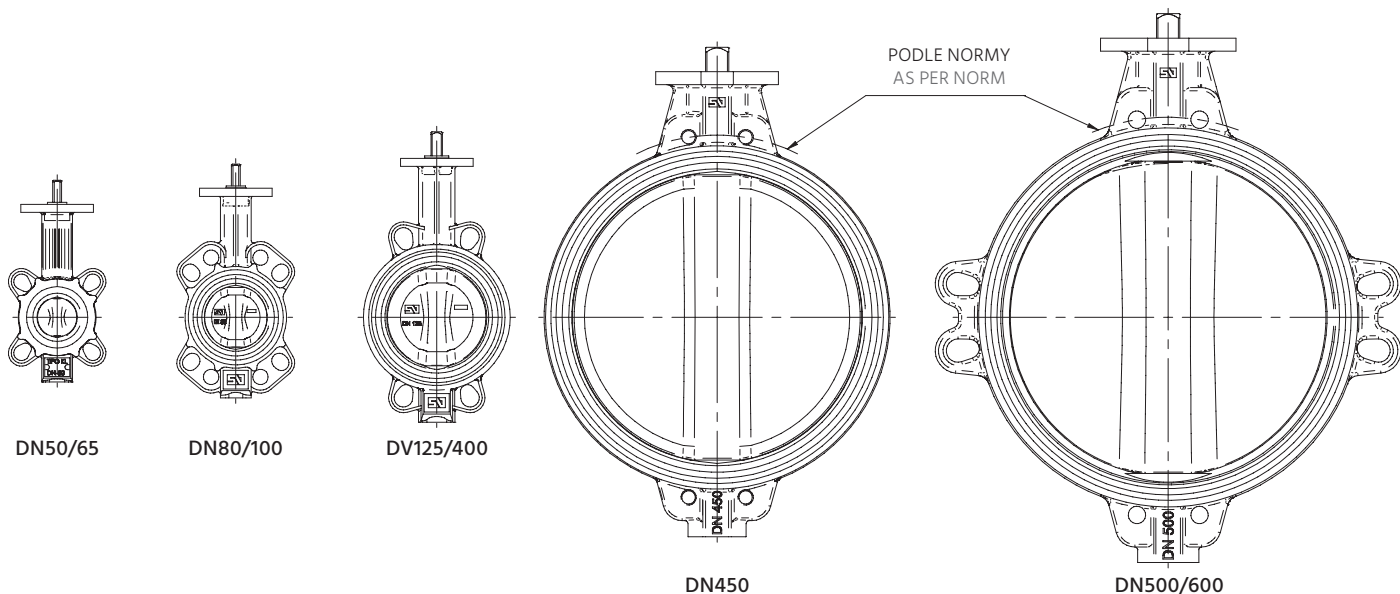

DN	50	65	80	100	125	150	200	250	300	350	400	450	500	600
PN.6	x	x	x	o	x	x	x	x	x	x	o	o	o	o
PN.10	x	x	x	x	x	x	x	x	x	x	x	x	x	x
PN.16	x	x	x	x	x	x	x	x	x	x	x	x	x	x
PN.20	x	x	x	x	x	x	x	x	x	x	x	x	x	x
ANSI 150 Lbs	x	x	x	x	x	x	x	x	x	x	x	x	x	x
AWWA				x	x	x	x	x	x	x	x	x	x	x
BS, D	o	-	o	o	x	x	x	o	x	x	o	x	o	o
BS, E	o	-	o	x	x	x	x	x	x	x	o	x	o	o
JIS 5k	-	x	o	-	x	x	o	x	x	o	o	o	o	o
JIS 10k	x	x	o	o	x	x	o	x	o	x	x	x	x	x
JIS 16k	o	o	o	o	o	o	o	o	o	o	x	x	x	x

X STANDARDNÍ / STANDARD
 O NA VYŽÁDÁNÍ / ON REQUEST
 - NENÍ MOŽNÉ / NOT POSSIBLE

MONTÁŽ MEZI PŘÍRUBY / ASSEMBLY BETWEEN FLANGES

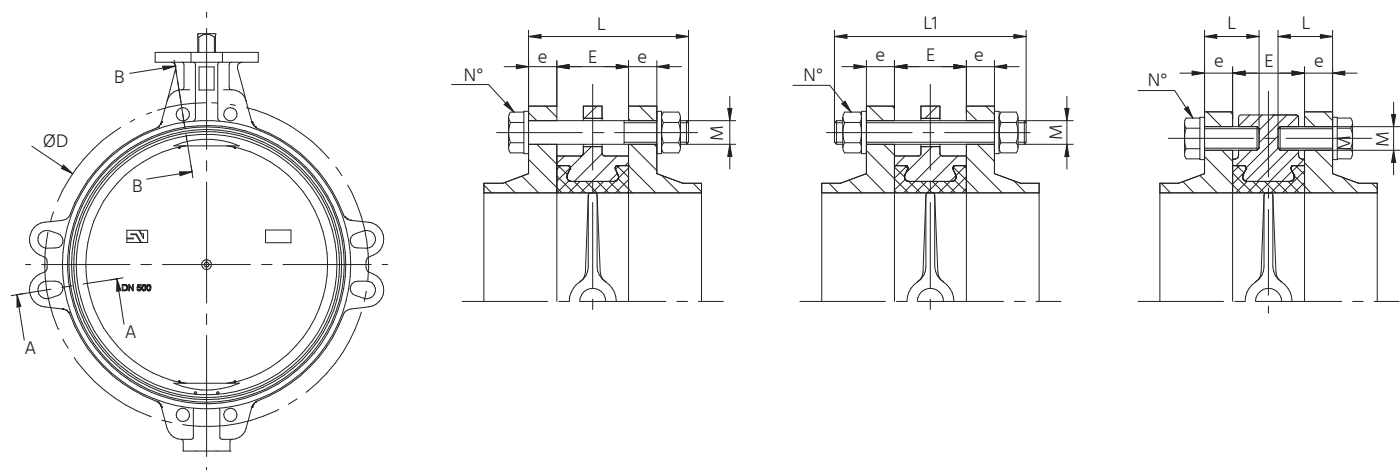

DN	E	PN10						PN16						ANSI 150 Lbs					
		D	e	M	L	L1	N°	D	e	M	L	L1	N°	D	e	M	L	L1	N°
50	43	125	18	M16	100	120	4	125	18	M16	100	120	4	120,6	19	5/8"	100	120	4
65	46	145	18	M16	100	120	4	145	18	M16	100	120	4	139,7	22,2	5/8"	110	130	4
80	46	160	20	M16	110	130	8	160	20	M16	110	130	8	152,4	23,8	5/8"	110	130	4
100	52	180	20	M16	110	130	8	180	20	M16	110	130	8	190,5	23,8	5/8"	120	140	8
125	56	210	22	M16	120	140	8	210	22	M16	120	140	8	215,9	23,8	3/4"	130	150	8
150	56	240	22	M20	130	150	8	240	22	M20	130	150	8	241,3	25,4	3/4"	130	150	8
200	60	295	24	M20	130	160	8	295	24	M20	130	160	12	298,5	28,6	3/4"	140	160	8
250	68	350	26	M20	150	170	12	355	26	M24	150	170	12	361,9	30,2	7/8"	160	180	12
300	78	400	26	M20	160	180	12	410	28	M24	160	180	12	431,8	31,7	7/8"	170	190	12
350	78	460	26	M20	170	180	16	470	30	M24	170	190	16	476,2	34,9	1"	180	200	12
400	102	515	26	M24	180	210	16	525	32	M27	200	220	16	539,7	36,5	1"	210	230	16
450	114	565	26	M24	190	220	16	585	32	M27	210	240	16	577,8	39,7	1 1/8"	230	250	16
				M24	60		8			M27	60		8						
500	127	620	28	M24	210	230	20	650	34	M30	230	260	20	635,0	46	1 1/8"	250	280	16
																1 1/8"	105		8
600	154	725	28	M27	240	270	20	770	36	M33	260	290	20	749,3	47,6	1 1/4"	280	310	20

UZAVÍRACÍ KLAPKY VV / BUTTERFLY VALVES VV



Typ tělesa / Body type	s drážkami pro připojení / with grooved ends
Rozsah DN / Production Range	DN 50–200
Konstrukce / Standard Design	EN 593
Stavební délka / Face to Face	podle výrobce / acc. to manufacturer
Vrchní příruba / Top Flange	EN ISO 5211 / NFE 29-402
Norma označení / Marking	EN 19
Max. pracovní tlak Max. working pressure	DN 50–200 16 bar
Pracovní teplota / Working temperature	-20 °C + 110 °C
Zkoušky armatur / Hydraulic tests	EN 12266 / ISO 5208

Uzavírací klapky s litým tělesem s drážkami pro připojení do potrubí rychloupínacími objímkami (spojkami) systému Victaulic se používají především tam, kde je nutné zajistit rychlé připojení do potrubí a omezit nežádoucí vibrace v potrubním systému. Dodávají se s EPDM těsněním navulkanizovaným na vnitřní povrch tělesa.

Butterfly valves with cast body and grooved ends for connecting to piping with Victaulic quick couplers are mainly used where it is necessary to ensure fast mounting between pipes and to reduce unwanted vibrations in the piping system. Valves are supplied with EPDM seal vulcanized to the inside of the body.

Oblasti použití / Applications

- Zavlažování
- Filtrační systémy
- Hasicí zařízení

- Irrigation
- Filter Systems
- Fire extinguishers



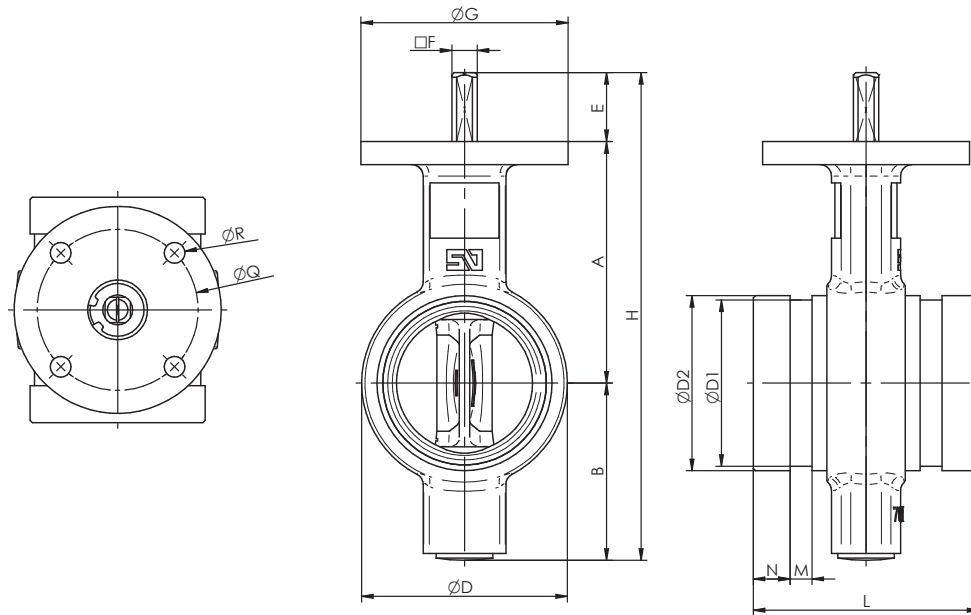

DN			ZÁKLADNÍ ROZMĚRY / GENERAL DIMENSIONS													VRCHNÍ PŘÍRUBA / TOP FLANGE			
mm	Inch	O.D.	A	B	D	D1	D2	E	F	G	H	L	M	N	váha	ISO	P	Q	R
50	2"	60,3	100	50	70	57,1	60,3	30	11	90	180	86	8	16	1,7	F-07	13	70	4x9
65	2-1/2"	76,1	105	77	89,5	72,3	76,1	30	11	90	212	97	9,5	16	2,3	F-07	13	70	4x9
80	3"	88,9	112	85	102	84,9	88,9	30	11	90	227	97	9,5	16	2,8	F-07	13	70	4x9
100	4"	114,3	135	97	128	110,1	114,3	30	11	90	262	116	9,5	16	3,9	F-07	13	70	4x9
125	5"	139,7	147	108	155	135,5	139,7	33	14	90	288	148	9,5	16	5,9	F-07	17	70	4x9
125	5"	141,3	147	108	155	137	141,3	33	14	90	288	148	9,5	16	6,1	F-07	17	70	4x9
150	6"	165,1	180	120	180	160,9	165,1	33	14	90	333	148	9,5	16	7,3	F-07	17	70	4x9
150	6"	168,3	180	120	180	164	168,3	33	14	90	333	148	9,5	16	7,8	F-07	17	70	4x9
200	8"	219,1	204	148	234	214,4	219,1	33	17	90	385	133	12,4	19	10,4	F-07	20,3	70	4x9

ROZMĚRY S OVLÁDÁNÍM / DIMENSIONS WITH OPERATING

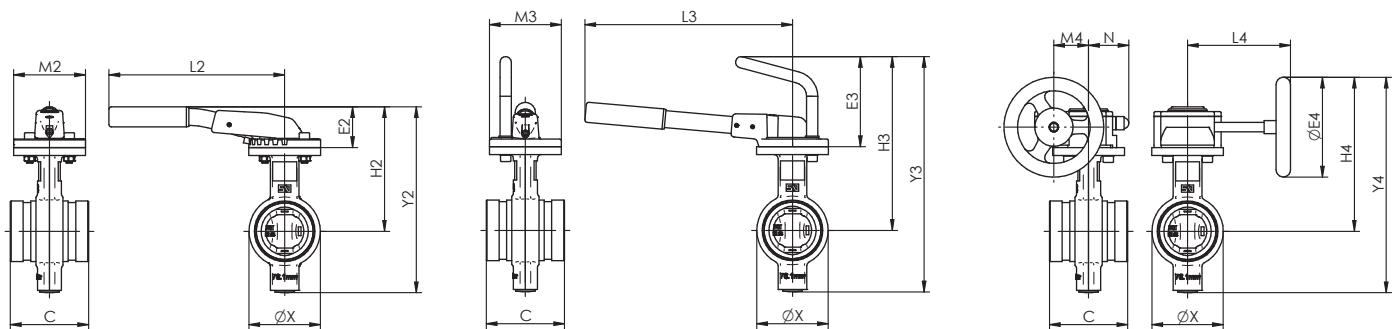

MN – ruční páka se zarážkami po 15°
/ hand lever with notches of 15°

MR – ruční páka s možností blokace v jakékoliv
pozici / hand lever with blocking in all positions

MDV - převod s ručním kolem
MDV - gearbox with handwheel

DN			MN								MN						MN							
mm	Inch	O.D.	C	X	E2	H2	Y2	L2	M2	Kg	E3	H3	Y3	L3	M3	Kg	REF	ØE4	H4	Y4	L4	M4	N	Kg
50	2"	60,3	86	70	49	149	199	220	90	2,1	113	213	263	260	90	2,3	0	125	188	238	129	43,5	50,5	2,9
65	2-1/2"	76,1	97	89,5	49	154	231	220	90	2,7	113	218	267	260	90	2,9	0	125	193	270	129	43,5	50,5	3,5
80	3"	88,9	97	102	60	172	257	260	90	3,3	13	225	310	260	90	3,4	0	125	200	285	129	43,5	50,5	4,0
100	4"	114,3	116	128	60	195	292	260	90	4,4	113	248	345	260	90	4,5	0	125	223	320	129	43,5	50,5	5,1
125	5"	139,7	148	155	75	222	330	315	90	6,5	113	260	368	310	90	6,6	1	160	252,5	360,5	135	43,5	50,5	7,3
125	5"	141,3	148	155	75	222	330	315	90	6,7	113	260	368	310	90	6,8	1	160	252,5	360,5	135	43,5	50,5	7,5
150	6"	165,1	148	180	75	255	375	315	90	7,9	113	293	413	310	90	8,0	1	160	285,5	405,5	135	43,5	50,5	8,7
150	6"	168,3	148	180	75	255	375	315	90	8,4	113	293	413	500	90	8,5	1	160	285,5	405,5	135	43,5	50,5	9,2
200	8"	219,1	133	234	75	279	427	315	90	11,0	113	317	465	500	90	11,1	1A	200	334	482	152	52,5	59	13,0

ROZMĚRY S OVLÁDÁNÍM PNEUMATICKÝM POHONEM / DIMENSIONS WITH PNEUMATIC ACTUATOR

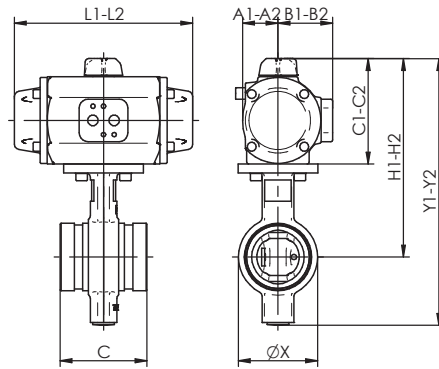

MND – dvojitý pneumatický pohon
 / double acting pneumatic actuator
 MNS – jednočinný (s vratnou pružinou)
 pneumatický pohon
 / single acting (spring return) pneumatic actuator

DN			MND											MNS						
mm	Inch	O.D.	C	X	REF	A1	B1	C1	H1	Y1	L1	Kg1	REF	A2	B2	C2	H2	Y2	L2	Kg2
50	2"	60,3	86	70	PA00	31,9	52,2	120,5	220,5	270,5	152,8	3,1	PA00S	31,9	52,2	120,5	220,5	270,5	152,8	3,3
65	2 1/2"	76,1	97	89,5	PA05	39,9	61,7	119	224	301	201,2	4,9	PA05S	39,9	61,7	119	224	301	201,2	5,3
80	3"	88,9	97	102	PA05	39,9	61,7	119	231	316	201,2	5,4	PA10S	40,9	62,7	123	235	320	225	6,3
100	4"	114,3	116	128	PA05	39,9	61,7	119	254	351	201,2	6,5	PA15S	48,9	70,5	138,6	273,6	370,6	265	8,9
125	5"	139,7	148	155	PA10	40,9	62,7	123	270	378	428	9,0	PA20S	52,4	75,1	146,8	293,8	401,8	310	12,5
125	5"	141,3	148	155	PA10	40,9	62,7	123	270	378	428	9,2	PA20S	52,4	75,1	146,8	293,8	401,8	310	12,7
150	6"	165,1	148	180	PA15	48,9	70,5	138,6	318,6	438,6	265	11,5	PA25S	64,3	89,2	174,8	264,8	474,8	358,2	18,6
150	6"	168,3	148	180	PA15	48,9	70,5	138,6	318,6	438,6	265	12,0	PA25S	64,3	89,2	174,8	264,8	474,8	358,2	19,1
200	8"	219,1	133	234	PA20	52,3	75,1	146,8	350,8	498,8	310	16,0	P30S	71,7	97,3	191,3	395,3	543,3	427,5	25,7

UZAVÍRACÍ KLAPKY TYP BBNV(W) / FFNV(W)

BUTTERFLY VALVES BBNV(W) / FFNV(W)



Typ tělesa / Body type	přírubové / flanged
Rozsah DN / Production Range	BBNV(W) DN 40–1 200 FFNV(W) DN 400–1000
Stavební délka / Face to Face	BBNV(W) EN 558-1, serie 13 FFNV(W) DN 558-1, serie 14
Vrchní příruba / Top Flange	EN ISO 5211 / NFE 29-402
Vrtání přírub / Drilling Norm	DIN PN 10/16, ANSI cl. 150
Norma označení / Marking	EN 19
Max. pracovní tlak Max. working pressure	16 bar DN 40–150 10 bar DN 200–1 200 (16 bar – na přání / on request)
Pracovní teplota / Working temperature	EPDM manžeta / liner: -20 °C + 110 °C NBR manžeta / liner: -10 °C + 90 °C
Zkoušky armatur / Hydraulic tests	EN 12266 / ISO 5208

Uzavírací klapky s litým přírubovým tělesem, navulkanizovanou měkkou manžetou a prodlouženou stavební délkou jsou cenově příznivější variantou k dvojexcentrickým uzavíracím klapkám. Konstrukce klapky umožňuje montáž na konec potrubí. V takovém případě je max. povolený pracovní tlak $0,4 \times PN$. Provozovat klapku na konci potrubí na plný tlak je možné pouze tehdy, pokud je zpevněná protipřírubou.

Butterfly valves with cast flanged body, vulcanized elastomer liner and elongated face to face dimension. The design of the valve allows its installation at the end of the pipeline. In this case, the maximum working pressure is $0.4 \times PN$. Butterfly valve under full pressure at the end of pipeline is possible to keep if it is reinforced with a counter flange only.

Oblasti použití / Applications

- ČOV, úprava a rozvody vody
- Energetika
- Plynárenství



- Waste water cleaning plants, water treatment and distribution
- Power industry
- Gas industry

BBNV(W) - ROZMĚRY / GENERAL DIMENSIONS

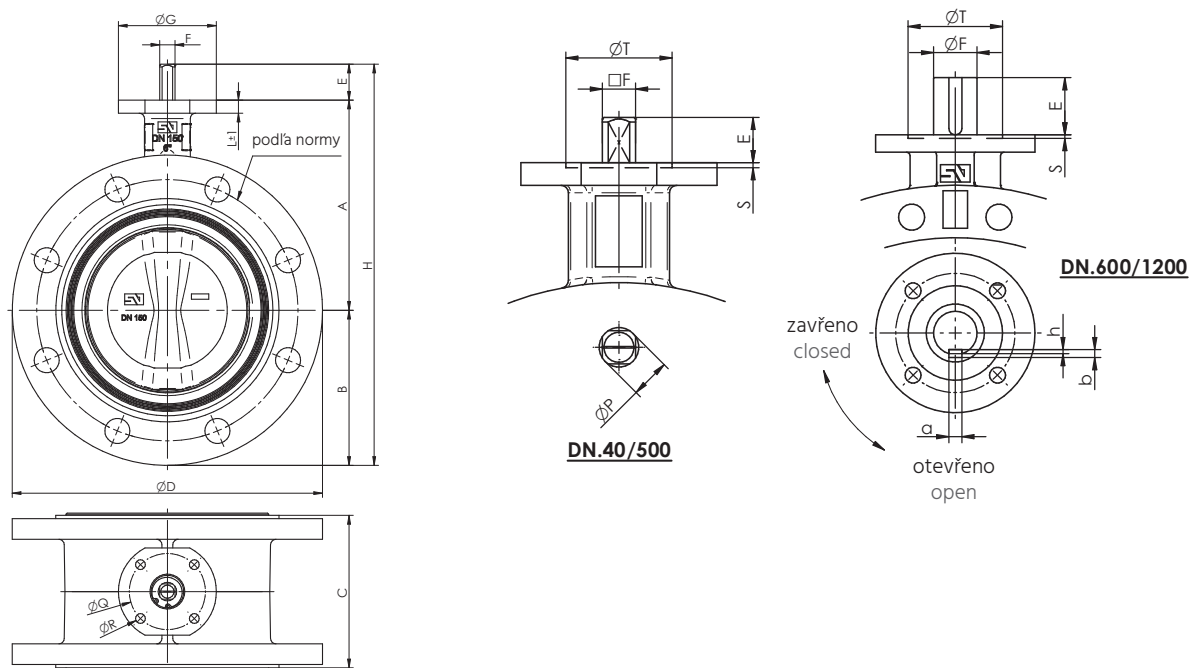

DN		ROZMĚRY / DIMENSIONS										VRCHNÍ PŘÍRUBA / TOP FLANGE								
mm	Inch	A	B	C	D	E	F	G	H	L	váha	ISO	P	Q	R	S	T	Pero-drážka Keyway		
																		a × b	h	
40	1-1/2"	110	75	106	150	30	11	90	215	10	7,33	F-07	13	70	4×9					
50	2"	120	82,5	108	165	30	11	90	232,5	10	8,42	F-07	13	70	4×9					
65	2-1/2"	135	92,5	112	185	30	11	90	257,5	10	9,5	F-07	13	70	4×9					
80	3"	141	100	114	200	30	11	90	271	10	10,7	F-07	13	70	4×9					
100	4"	165	114,5	127	229	30	11	90	309,5	10	13,1	F-07	13	70	4×9					
125	5"	180	127	140	254	33	14	90	340	12	18,69	F-07	17	70	4×9					
150	6"	193	143	140	285	33	14	90	369	12	20,75	F-07	17	70	4×9					
200	8"	225	171,5	152	343	33	17	90	429,5	12	33,4	F-07	20,3	70	4×9					
250	10"	282,5	210	165	406	30	22	130	522,5	14	48,8	F-10	26,2	102	4×12	3	70			
300	12"	308	240	178	480	30	22	130	579,5	14	71,9	F-10	26,2	102	4×12	3	70			
350	14"	338,5	271	190	535	31	22	160	637,5	15	93,4	F-10	28	102	4×12	3	70			
400	16"	380	308	216	597	31	27	160	719	18	122	F-12	33	125	4×14	4	85			
450	18"	380,5	340	222	640	38	36	190	758,5	20	172,6	F-14	48	140	4×18	4	100			
500	20"	432,5	380	229	715	38	36	210	850,5	20	207	F-14	48	140	4×18	4	100			
600	24"	494	440	267	840	80	60	210	1014	24	311,3	F-16		165	4×22	5	130	18×11	7	
700	28"	590	490	292	927	106	65	300	1186	30	448,3	F-25		254	8×18	5	200	18×11	7	
750	30"	590	530	318	985	106	80	300	1226	25	485	F-25		254	8×18	5	200	22×14	9	
800	32"	630	565	318	1060	106	80	300	1301	28	575	F-25		254	8×18	5	200	22×14	9	
900	36"	695	610	330	1170	110	80	350	1415	32	832,4	F-25		254	8×18	5	200	22×14	9	
1000	40"	770	675	410	1290	110	80	350	1555	32	972,6	F-25		254	8×18	5	200	22×14	9	
1100	44"	815	733	410	1405	110	80	350	1658	32	1485,6	F-25		254	8×18	5	200	22×14	9	
1200	48"	875	818	470	1510	110	100	350	1803	40	1806	F-30		298	8×23	5	230	28×16	10	

FFNV(W) - ROZMĚRY / GENERAL DIMENSIONS

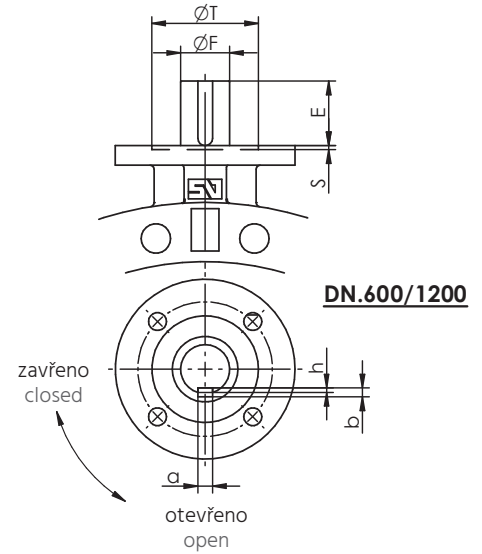
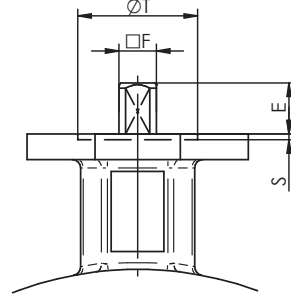
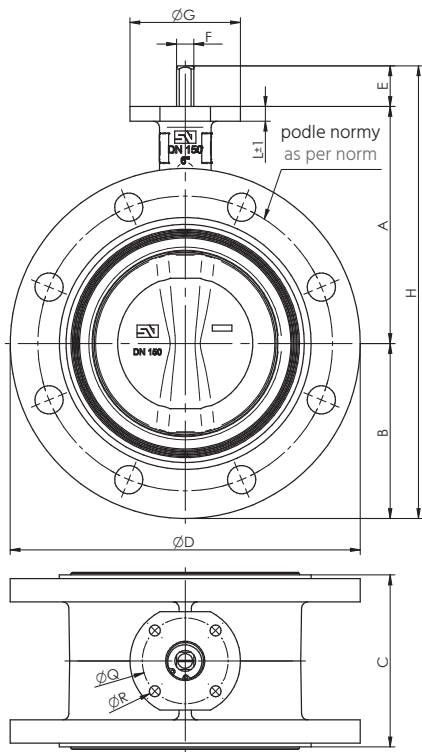

DN		ROZMĚRY / DIMENSIONS									VRCHNÍ PŘÍRUBA / TOP FLANGE								
mm	Inch	A	B	C	D	E	F	G	K			váha weight	ISO	Q	R	S	T	Pero-drážka Keyway	
									PN10	PN16	Cl.150							a × b	h
400	16"	380	308	310	597	31	27	160	515	525	539,7	132	F-12	125	4×14	4	85		
450	18"	381	340	330	640	38	36	190	565	585	577,8	171	F-14	140	4×18	4	100		
500	20"	433	380	350	715	38	36	210	620	650	635,0	225	F-14	140	4×18	4	100		
600	24"	494	440	390	840	80	60	210	725	770	749,3	346	F-16	165	4×22	5	130	18×11	7
700	28"	560	485	430	927	106	65	300	840	840	863,5	453	F-25	254	8×18	5	200	18×11	7
750	30"	590	530	470	995	106	80	300	900	900	914,4	545	F-25	254	8×18	5	200	22×14	9
800	32"	630	565	470	1060	106	80	300	950	950	978	613	F-25	254	8×18	5	200	22×14	9
900	36"	695	610	510	1170	110	80	350	1050	1050	1086	808	F-25	254	8×18	5	200	22×14	9
1000	40"	770	675	550	1290	110	80	350	1160	1170	1200	1007	F-25	254	8×18	5	200	22×14	9
1100	44"	815	733	550	1405	110	80	350	1270	1270	1314,5	1295	F-25	254	8×18	5	200	22×14	9
1200	48"	875	818	630	1510	110	100	350	1380	1390	1422	1660	F-30	298	8×23	5	230	28×16	10

ROZMĚRY S OVLÁDÁNÍM / DIMENSIONS WITH OPERATING

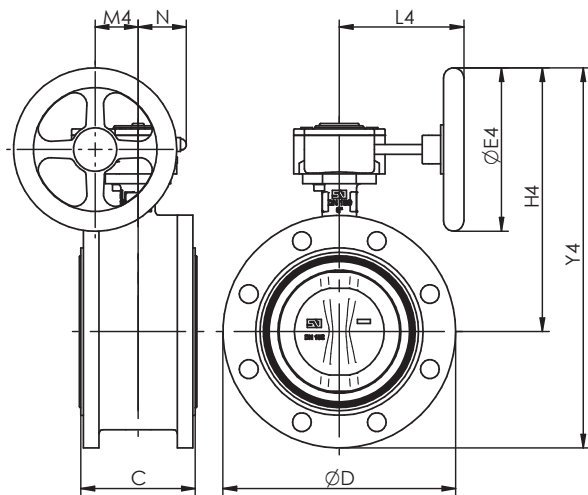

MDV - převod s ručním kolem
MDV - gearbox with handwheel

DN		MDV									
mm	Inch	C	ØD	Typ / Type	ØE4	H4	Y4	L4	M4	N	Kg
400	16"	310	597	2A	300	572,5	880,5	278	68,8	72,5	130,9
450	18"	330	640	3	400	630,5	970,5	321	96,5	91,5	191,0
500	20"	350	715	3	400	682,5	1 063	321	96,5	91,5	225,4
600	24"	390	840	4	500	798,5	1 239	408	137,5	140	345,5
700	28"	430	927	4	600	944,5	1 435	424	137,5	140	489,3
750	30"	470	985	5	600	944,5	1 475	456	137,5	140	526,0
800	32"	470	1 060	5	600	984,5	1 550	456	137,5	140	635,6
900	36"	510	1 170	6	700	1 109	1 719	510	180	156	893,0
1 000	40"	550	1 290	7	700	1 184	1 859	579	180	156	1 039
1 100	44"	550	1 405	7	700	1 229	1 962	579	180	156	1 681
1 200	48"	630	1 510	8	700	1 310	2 128	593	252	228	2 002



Moravia Systems a.s.

Sídlo společnosti/Legal address

Vinohradská 1511/230
CZ – 100 00 Praha 10
+420 518 777 111
info@moraviasystems.cz

Obchodní oddělení/Sales Department

T: +420 255 715 715
armatury@moraviasystems.cz



INTERMOS VALVES s.r.o.

Obchodní zastoupení pro Slovenskou republiku
Representation in Slovak Republic

Moskovská 13
SK – 811 08 Bratislava – Staré Mesto
+421 910 933 338
info@intermos.sk