

S38 111 540

DN 40 – DN 300 / PN 40 OS & Y GATE VALVE, FLANGED TYPE



- outside screw and yoke
- cast body and bonnet
- flexible wedge
- stainless steel sealing surfaces
- asbestos-free packing

APPLICATION:

- water, steam, oil or gas distribution
- industrial equipment
- production technology
- petrochemical or chemical industry

ADVANTAGES:

- compliance with emission standards
- easy installation and maintenance
- possibility of replacement of packing under pressure
- long service life



TECNICAL DATA:

Working range: water, steam, natural gas, oil, petroleum derivatives and another non-aggressive working fluids; temperature range: -29 °C to +400 °C

The allowable pressure/temperature rating: EN 12516-1:2014

Construction materials: carbon steel (please see more in table of Material of main parts)

The gate valves are bidirectional valves designed to fully open or close of the flow of working fluid. They are not intended for throttling or regulation.

The gate valves can also be used for slightly to moderately soiled working media; they are not suitable for media containing gross mechanical impurities that can cause problems with closing of valves or erosion of seats.

Note: In order to determine suitable valve for use with a specific working medium we recommend you to contact our sales department.

Face to face: EN 558-1, serie 26

Flanges: EN 1092-1, B1 / DIN PN40

Operating: hand wheel

Options: hand wheel with lock
hand wheel with limit switches
operating by electric actuator
operating from stand or by grounding kit
other types of coatings according to customer requirements
delivery including counter-flanges, bolting and sealing material

Testing:

each valve is tested according to EN 12266 and supplied with accompanying documentation according to EN 10204

Certification:

PED 2014/68/ EU

DESIGN AND CONSTRUCTION MATERIALS

Picture 1 DN 40– 150

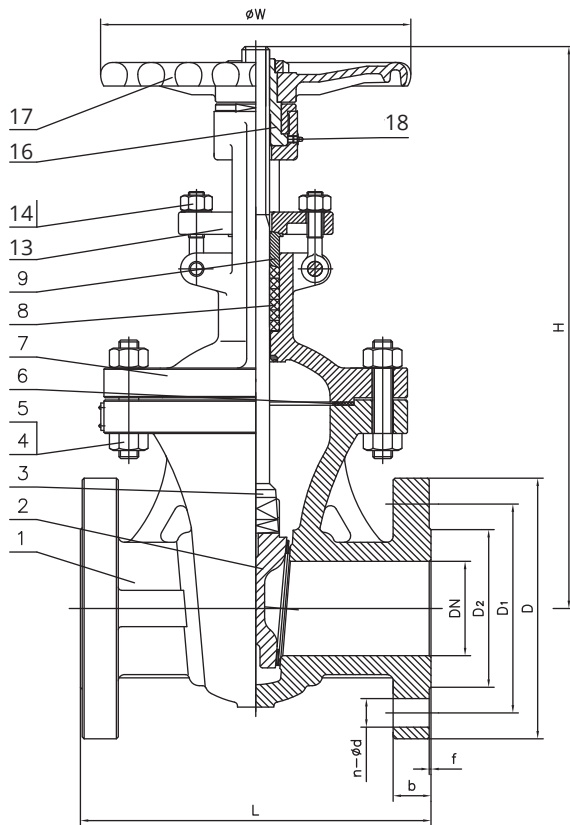

Picture 2 DN 200–300

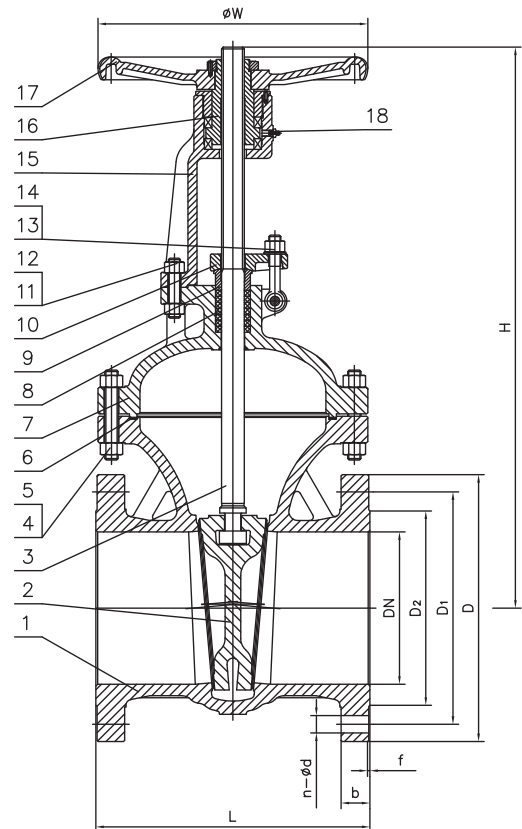

Table 1 Materials of main parts

Position	Description	Material
1	Body ¹⁾	GP240GH+13Cr
2	Wedge	GP240GH+13Cr
3	Stem	ASTM A182 F6a
4	Bolt of bonnet	ASTM A193 B7
5	Nut of bonnet	ASTM A194 2H
6	Bonnet sealing	Graphit + AISI304
7	Bonnet ¹⁾	GP240GH
8	Packing	Graphit
9	Packing gland	ASTM A182 F6a
10	Flange of packing	GP240GH
11	Bolt ¹⁾	ASTM A193 B7
12	Nut	ASTM A194 2H
13	Eye bolt	ASTM A193 B7
14	Nut	ASTM A194 2H
15	Yoke ¹⁾	GP240GH
16	Stem nut	Copper alloy
17	Hand wheel	Nodular cast iron
18	Lubricator	Carbon steel

¹⁾ with epoxy paint 100 -150 µm, RAL 5002

DIMENSIONS

Dimensions (mm)											Weight
DN	PN	D	D1	D2	b	f	n-ød	L	H	øW	kg
40	40	150	110	88	18	3	4-ø18	240	323	200	22
50	40	165	125	102	18	3	4-ø18	250	377	200	26
65	40	185	145	122	22	3	8-ø18	290	389	250	39
80	40	200	160	138	24	3	8-ø18	310	418	250	44
100	40	235	190	162	24	3	8-ø22	350	489	300	63
125	40	270	220	188	26	3	8-ø26	400	541	300	95
150	40	300	250	218	28	3	8-ø26	450	630	360	126
200	40	375	320	285	34	3	12-ø30	550	824	820	223
250	40	450	285	345	38	3	12-ø33	650	915	450	322
300	40	515	450	410	42	4	16-ø33	750	1085	500	525

The data in this datasheet are informative only and the manufacturer reserves the right to changes of technical details.