

VENS

DN 15 ÷ 250
PN 63 / PN 100 / PN 160
GLOBE VALVES

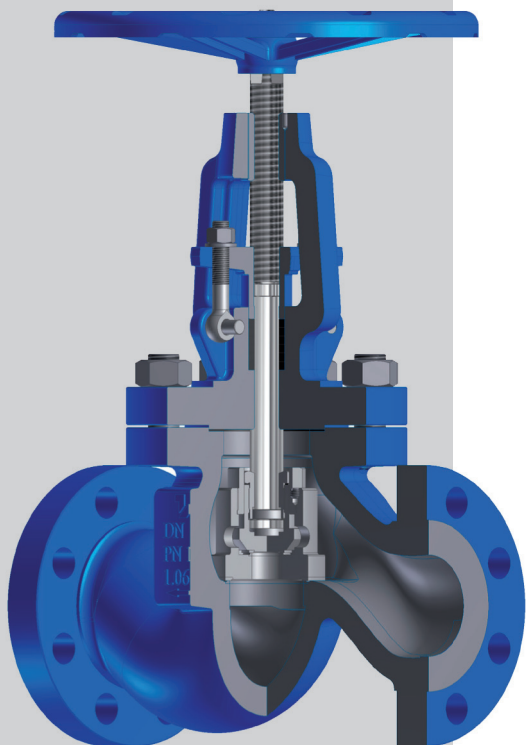

- Standard: EN 13709
- Forged or casted body and bonnet
- Bolted bonnet (BB)
- Rising stem (RS), outside screw and yoke (OS&Y)
- Seats are integral or welded on

APPLICATIONS

- Power plant
- Chemical
- Petrochemical
- Refining

ADVANTAGES

- Long service life
- Respect to emission standards
- Easy handling and maintenance
- Stem packing replacement in working conditions



TECHNICAL DATA

Media:	Depending on the valve materials: water, steam, gas, oil and oil derivatives and other non aggressive media
Pressure and temperature:	Pressure up to 160 bar Temperature up to 600 °C
Materials:	Carbon, heat resistant alloy and stainless steels
Další možnosti:	Electric, hydraulic or pneumatic actuator Y-Type (VENSY) Angle type (VENSA) Position indicator Extended stem Inside screw rising stem (IS&RS) Spring loaded stuffing box (SLSB) Locking device Seats and sealings made of elastomeric and polymeric materials Flanges and welding ends according to: GOST, DIN, ASME, etc Other paint finishes are available upon customer's request Valve complete with counter flanges, bolting and gaskets
Testing:	Every produced valve was tested according to EN 12266

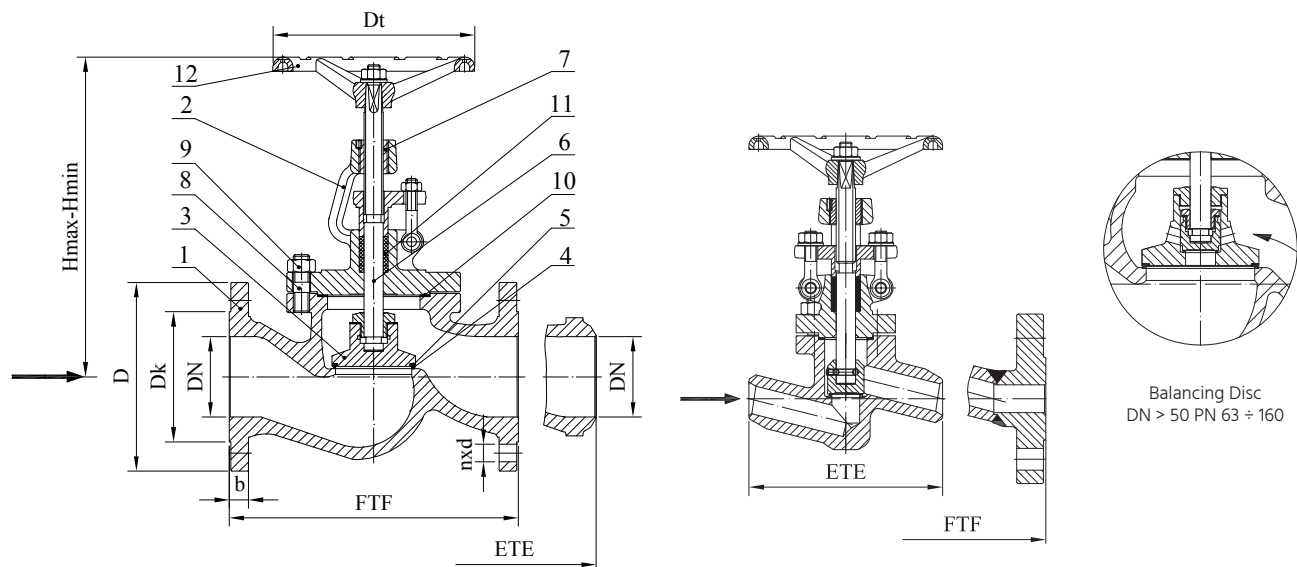

LIST OF MATERIALS

Item	Part	Material Group acc. to EN 12516-1					
		3E0	4E0	5E0	6E0	11E0	15E0 / 14E0
		Application					
		T ≤ 400 °C	T ≤ 550 °C	T ≤ 550 °C	T ≤ 600 °C	-196 °C ÷ 600 °C	-196 °C ÷ 600 °C
1	Body ¹⁾	1.0460 / 1.0619	1.5415 / 1.5419	1.7335 / 1.7357	1.7383 / 1.7379	1.4301 / 1.4308	1.4571 / 1.4408
2	Bonnet ¹⁾	1.0460 / 1.0619	1.5415 / 1.5419	1.7335 / 1.7357	1.7383 / 1.7379	1.4301 / 1.4308	1.4571 / 1.4408
3	Disc ¹⁾	1.4021 / 1.0619	1.5415 / 1.5419	1.7335 / 1.7357	1.7383 / 1.7379	1.4301 / 1.4308	1.4571 / 1.4408
4	Body welded on with	13Cr	17Cr (up to 450 °C) or Stellite			Basic material or Stellite	
5	Disc welded on with	13Cr	17Cr (up to 450 °C) or Stellite			Basic material or Stellite	
6	Stem	1.4021 / 1.4122				1.4301	1.4571
7	Stem Nut	1.0715 / 1.7225 / Cu alloy					
8	Stud Bolts	A193 B7 / 1.7225		A193 B16 / 1.7709		A193 B8 / 1.4301	A193 B8M / 1.4401
9	Nuts	A194 2H / 1.1191		A194 4 / 1.7709		A194 8 / 1.4301	A193 8M / 1.4401
10	Bonnet Gasket	spiral-wound / reinforced pure graphite					
11	Stem Packing	graphite with corrosion inhibitor					
12	Handwheel	epoxy coated steel					

1) other materials available according to EN standard

STANDARDS

Globe Valves according to EN 13709	PN63 / PN 100 / PN 160
Face-to face dimensions according to	EN 558, Serie 2
Flanged ends according to	EN 1092-1
End-to-end dimensions according to	EN 12982, Serie 65
Welding ends according to	EN 12627

DIMENSIONS PN 63

DN		15	20	25	32	40	50	65	80	100	125	150	200	250
[mm]	FTF	210	230	230	260	260	300	340	380	430	500	550	650	775
	ETE	150	150	160	180	210	250	340	380	430	500	550	650	775
	D	105	130	140	155	170	180	205	215	250	295	345	415	470
	Dk	75	90	100	110	125	135	160	170	200	240	280	345	400
	nxd	4×14	4×18	4×18	4×22	4×22	4×22	8×22	8×22	8×26	8×30	8×33	12×36	12×36
	b	20	22	24	26	28	26	26	28	30	34	36	42	46
	Hmax	235	235	235	315	315	370	415	492	585	635	705	960	1160
	Hmin	220	220	220	295	295	334	385	457	540	580	645	870	1006
	Dt	150	150	150	200	200	250	300	300	400	400	500	500	630
kg	FTF	6,8	8,5	10	17	18	32	48	73	112	175	268	343	835
	ETE	4,8	4,8	5	12	14	24	39	60	100	155	238	310	770

DIMENSIONS PN 100

DN		15	20	25	32	40	50	65	80	100	125	150	200	250
[mm]	FTF	210	230	230	260	260	300	340	380	430	500	550	650	775
	ETE	150	150	160	180	210	250	340	380	430	500	550	650	775
	D	105	130	140	155	170	195	220	230	265	315	355	430	505
	Dk	75	90	100	110	125	145	170	180	210	250	290	360	430
	nxd	4×14	4×18	4×18	4×22	4×22	4×26	8×26	8×26	8×30	8×33	12×33	12×36	12×39
	b	20	22	24	26	28	30	34	36	40	40	44	52	60
	Hmax	235	235	235	315	315	370	415	492	585	635	705	960	1160
	Hmin	220	220	220	295	395	334	385	457	540	580	645	870	1006
	Dt	150	150	150	200	200	250	300	300	400	400	500	500	630
kg	FTF	7	9	11	18	21	35	50	77	117	188	280	500	865
	ETE	4,8	4,8	5	12	14	24	39	60	100	155	238	446	770

DIMENSIONS PN 160

DN		15	20	25	32	40	50	65	80	100	125	150	200
[mm]	FTF	210	230	230	260	260	300	340	380	430	500	550	650
	ETE	150	150	160	180	210	250	340	380	430	500	550	650
	D	105	130	140	155	170	195	220	230	265	315	355	430
	Dk	75	90	100	110	125	145	170	180	210	250	290	360
	nxd	4×14	4×18	4×18	4×22	4×22	4×26	8×26	8×26	8×30	8×33	12×33	12×36
	b	20	22	24	26	28	30	34	36	40	44	50	60
	Hmax	235	235	235	315	315	370	415	492	585	635	705	960
	Hmin	220	220	220	295	295	334	385	457	540	580	645	870
	Dt	150	150	150	200	200	250	300	300	400	400	500	500
kg	FTF	7	9	11	18	21	35	50	79	124	192	288	510
	ETE	4,8	4,8	5	12	14	24	39	60	100	155	238	446

RANGE OF APPLICATION

Materials	PN	Pressure (bar) / Temperature (°C) ratings according to EN 12516-1																						
		-10	20	50	100	150	200	250	300	350	375	400	425	450	470	475	480	500	510	525	550	575	600	
1,0460 1,0619	63	63,0	63,0	63,0	59,0	55,9	52,9	48,4	43,8	40,8	39,3	37,8												
	100	100,0	100,0	100,0	93,6	88,8	84,0	76,8	69,6	64,8	62,4	60,0												
	160	160,0	160,0	160,0	149,8	142,1	134,5	122,9	111,4	103,7	99,9	96,0												
1,5415 1,5419	63	63,0	63,0	63,0	61,6	57,5	53,7	49,9	46,9	46,1	45,4	43,7	42,0	41,4	41,3	41,1	28,6	24,9	17,8	10,1				
	100	100,0	100,0	100,0	97,8	91,2	85,2	79,2	74,4	73,2	72,0	69,4	66,7	65,8	65,5	65,3	45,3	39,5	28,3	16,0				
	160	160,0	160,0	160,0	160,0	156,6	146,0	136,4	126,8	119,1	117,2	115,3	111,0	106,8	105,3	104,9	104,5	72,6	63,2	45,2	25,6			
1,7335 1,7357	63	63,0	63,0	63,0	63,0	63,0	63,0	63,0	63,0	58,7	56,5	53,8	51,4	49,7	47,2	46,5	45,5	39,3	35,1	28,9	18,5			
	100	100,0	100,0	100,0	100,0	100,0	100,0	100,0	100,0	93,1	89,8	85,3	81,6	78,9	74,9	73,9	72,2	62,4	55,8	45,9	29,3			
	160	160,0	160,0	160,0	160,0	160,0	160,0	160,0	160,0	149,1	143,7	136,6	130,7	126,2	119,8	118,2	115,6	99,9	89,3	73,4	47,0			
1,7383 1,7379	63	63,0	63,0	63,0	63,0	63,0	63,0	63,0	63,0	59,1	57,0	53,8	51,4	49,7	47,2	46,5	45,5	41,5	40,0	33,9	22,2	21,7	9,4	
	100	100,0	100,0	100,0	100,0	100,0	100,0	100,0	100,0	93,8	90,5	85,3	81,6	78,9	74,9	73,9	72,2	65,8	63,5	53,9	35,2	34,4	14,9	
	160	160,0	160,0	160,0	160,0	160,0	160,0	160,0	160,0	150,2	144,9	136,6	130,7	126,2	119,8	118,2	115,6	105,3	101,7	86,2	56,3	55,1	23,9	
1,4301 1,4308	63	63,0	63,0	63,0	58,2	51,2	44,1	41,5	38,8	36,0	35,1	34,2	33,3	32,5	31,9	31,8	31,6	31,0	30,7	28,7	27,9	25,2	19,8	
	100	100,0	100,0	100,0	92,4	81,2	70,0	65,8	61,6	57,1	55,7	54,3	52,9	51,5	50,6	50,4	50,2	49,3	48,7	45,6	44,3	40,0	31,5	
	160	160,0	160,0	160,0	147,9	130,0	112,1	105,3	98,6	91,4	89,2	87,0	84,7	82,5	81,0	80,7	80,3	78,9	78,0	73,0	70,9	64,0	50,4	
1,4408	63	63,0	63,0	63,0	60,0	53,8	47,6	44,1	40,6	38,8	37,9	37,0	36,2	35,6	35,4	35,3	35,2	34,9	34,8	32,9	32,6	27,6	22,8	
	100	100,0	100,0	100,0	95,2	85,4	75,6	70,0	64,4	61,6	60,2	58,8	57,4	56,6	56,1	56,0	55,9	55,4	55,2	52,3	51,7	43,7	36,3	
	160	160,0	160,0	160,0	152,4	136,7	121,0	112,1	103,1	98,6	96,4	94,1	91,9	90,5	89,8	89,6	89,5	88,7	88,4	83,7	82,8	70,0	58,1	
1,4571	63	63,0	63,0	63,0	60,9	56,4	53,8	51,2	48,5	47,2	45,9	45,0	44,1	43,4	43,2	43,0	41,5	40,0	37,9	36,7	33,9	24,5		
	100	100,0	100,0	100,0	96,6	89,6	85,4	81,2	77,0	74,9	72,8	71,4	70,0	68,9	68,6	68,3	65,8	63,5	60,2	58,2	53,9	38,9		
	160	160,0	160,0	160,0	154,6	143,4	136,7	130,0	123,3	119,9	116,5	114,3	112,1	110,3	109,8	109,4	105,3	101,7	96,3	93,2	86,2	62,3		

OPTIONAL EXECUTION

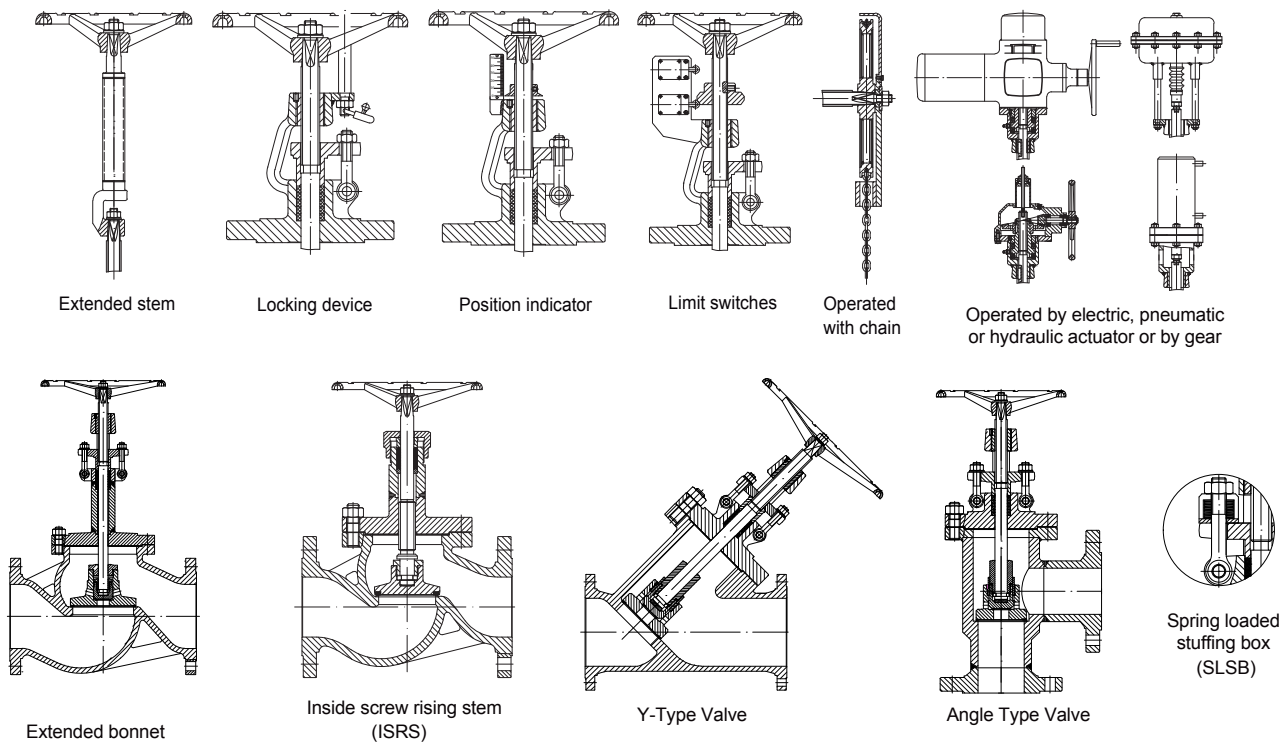

The data in this datasheet are informative only and the manufacturer reserves the right to changes of technical details.