

S30 111 516

DN 40 – DN 300 / PN 16
OS & Y GATE VALVE, FLANGED TYPE



- outside screw and yoke
- cast body and bonnet
- flexible wedge
- stainless steel sealing surfaces
- asbestos-free packing

APPLICATIONS:

- water, steam, oil or gas distribution
- industrial equipment
- production technology
- petrochemical or chemical industry



ADVANTAGES:

- short face to face
- compliance with emission standards
- easy installation and maintenance
- possibility of replacement of packing under pressure
- long service life

TECNICAL DATA:

Working range: water, steam, natural gas, oil, petroleum derivatives and another non-aggressive working fluids; temperature range: -29 °C to +400 °C

The allowable pressure/temperature rating: EN 12516-1:2014

Construction materials: carbon steel (please see more in table of Material of main parts)

The gate valves are bidirectional valves designed to fully open or close of the flow of working fluid. They are not intended for throttling or regulation.

The gate valves can also be used for slightly to moderately soiled working media; they are not suitable for media containing gross mechanical impurities that can cause problems with closing of valves or erosion of seats.

Note: In order to determine suitable valve for use with a specific working medium we recommend you to contact our sales department.

Face to face: according to manufacturer (CSN 133045)

Flanges: EN 1092-1, B1/DIN PN16

Operating: hand wheel

Options: hand wheel with lock
hand wheel with limit switches
operating by electric actuator
operating from stand or by grounding kit
other types of coatings according to customer requirements
delivery including counter-flanges, bolting and sealing material

Testing:

each valve is tested according to EN 12266 and supplied with accompanying documentation according to EN 10204

Certification:

PED 2014/68/ EU

DESIGN AND CONSTRUCTION MATERIALS

Table.1 DN 40–200

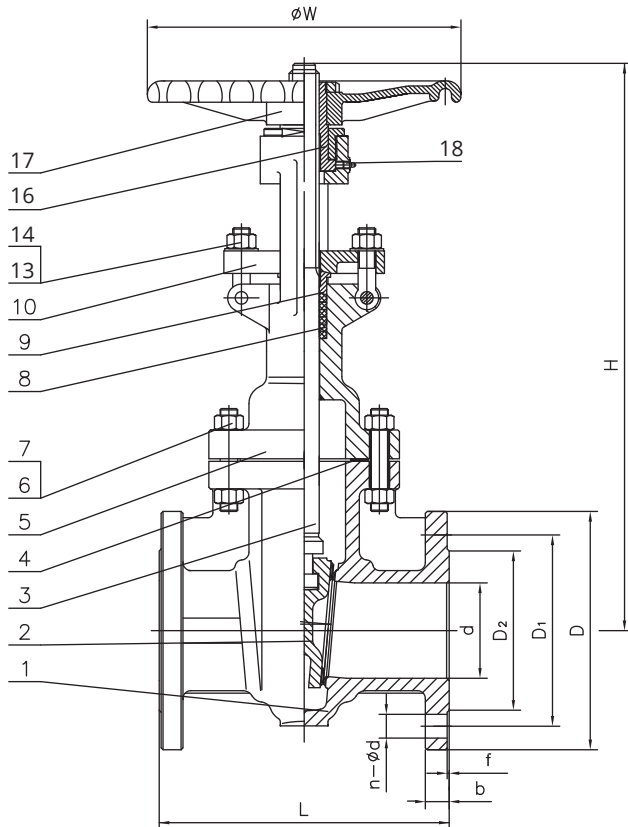

Table.2 DN 250–300

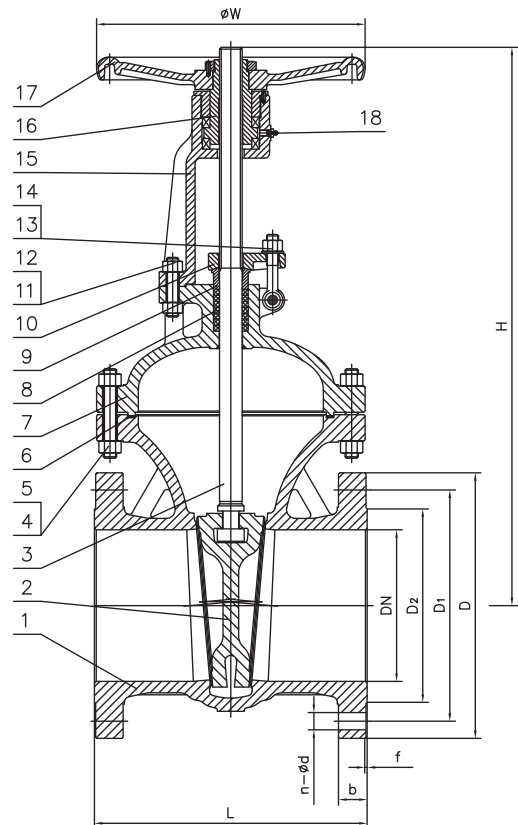

Table 1 Materials of main parts

Position	Description	Material
1	Body ¹⁾	GP240GH+13Cr
2	Wedge	GP240GH+13Cr
3	Stem	ASTM A182 F6a
4	Bolt of bonnet	ASTM A193 B7
5	Nut of bonnet	ASTM A194 2H
6	Bonnet sealing	Graphit + AISI304
7	Bonnet ¹⁾	GP240GH
8	Packing	Graphit
9	Packing gland	ASTM A182 F6a
10	Flange of packing ¹⁾	GP240GH
11	Bolt	ASTM A193 B7
12	Nut	ASTM A194 2H
13	Eye bolt	ASTM A193 B7
14	Nut	ASTM A194 2H
15	Yoke ¹⁾	GP240GH
16	Stem nut	Copper alloy
17	Hand wheel	Nodular cast iron
18	Lubricator	Carbon steel

¹⁾ with epoxy paint 100-150 μm , RAL 5002

DIMENSIONS

Dimensions (mm)											Weight
DN	PN	D	D1	D2	b	f	n-ød	L	H	øW	kg
40	16	150	110	88	18	3	4-ø18	170	295	200	15
50	16	165	125	102	18	3	4-ø18	180	305	200	18
65	16	185	145	122	18	3	4-ø18	200	345	200	24
80	16	200	160	138	20	3	8-ø18	210	370	250	28
100	16	220	180	158	20	3	8-ø18	230	445	280	37
125	16	250	210	188	22	3	8-ø18	255	530	280	51
150	16	285	240	212	22	3	8-ø22	280	565	300	73
200	16	340	295	268	24	3	12-ø22	330	725	350	140
250	16	405	355	320	26	3	12-ø26	450	905	400	225
300	16	460	410	378	28	4	12-ø26	500	1020	450	300

The data in this datasheet are informative only and the manufacturer reserves the right to changes of technical details.