



- design BS 5351
- full bore
- split body, floating ball, PTFE seats
- ISO 5211 top flange
- DN \geq 25 antistatic device
- fire safe BS 6755, API 6FA, API 607

APPLICATION:

- piping systems for processing, treatment and transport of liquid and gaseous media

ADVANTAGES:

- low weight
- low pressure loss
- space saving construction
- easy installation and maintenance
- reliability
- possibility of automatic operation

TECHNICAL DATA:

Working fluid: non-aggressive liquids and gases (water, steam, oil, air, fuel gases, oil and oil derivatives) depending on construction materials of valve

Working temperature: from -10 °C to +180 °C

Max. working pressure: 4 MPa, more in Pressure/Temperature Diagram

Construction materials: more in table of Materials of main construction parts

Face to face: acc. to manufacturer

Mounting between flanges acc. to EN 1092-1, B1 / PN 40

The ball valve is a two-way shut-off valve intended for installation in horizontal or vertical piping. The shut-off element is a ball with a through hole, which rotates through 90° and closes the working fluid flow in the seats. The ball valve is not suitable for abrasive working media and coagulating liquids. It is designed to operate either in the OPEN or CLOSED position.

Operating: hand wheel

Option: from DN150 gearbox with hand wheel on request
 elektric or pneumatic operating
 antistatic device for DN15–DN20
 degreasing service
 delivery including counter-flanges, sealing and bolting material

Testing: each ball valve shall be tested in accordance with EN 12266 and supplied with accompanying documentation according to EN 10204

Certification: PED 2014/68/ EU
 ATEX 94/9/ CE

DESIGN AND CONSTRUCTION MATERIALS

Fig. 1 DN15–DN100 JADE type

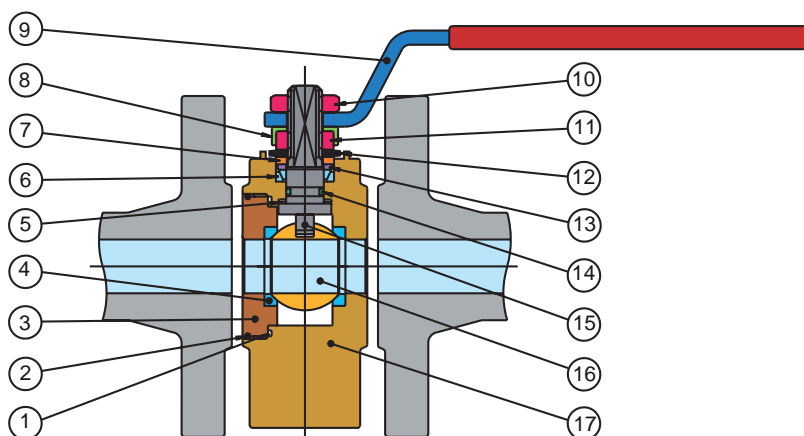

Table 1 Materials of main construction parts

Pos.	Description	Material
1	Gasket	PTFE
2	O-ring	NBR
3	2. part of body	ASTM A 105
4	Seats	PTFE
5	Washer	PTFE
6	Packing	PTFE
7	Operation - stop	AISI 304 (DIN 1.4301)
8	Fixing nut	AISI 304 (DIN 1.4301)
9	Hand lever	Fe P02 pozink.
10	Locking nut	steel galvanized
11	Retaining ring	steel galvanized
12	Spring washer	50 Cr V4
13	Thrust washers	AISI 304 (DIN 1.4301)
14	O-ring	FKM
15	Stem	AISI 304 (DIN 1.4301)
16	Ball	DN 15/40 AISI 316 (DIN 1.4401) DN 50/100 AISI 304 (DIN 1.4301)
17	2. part of body	ASTM A 105

Fig. 2 DN125–DN200 DIAMOND type

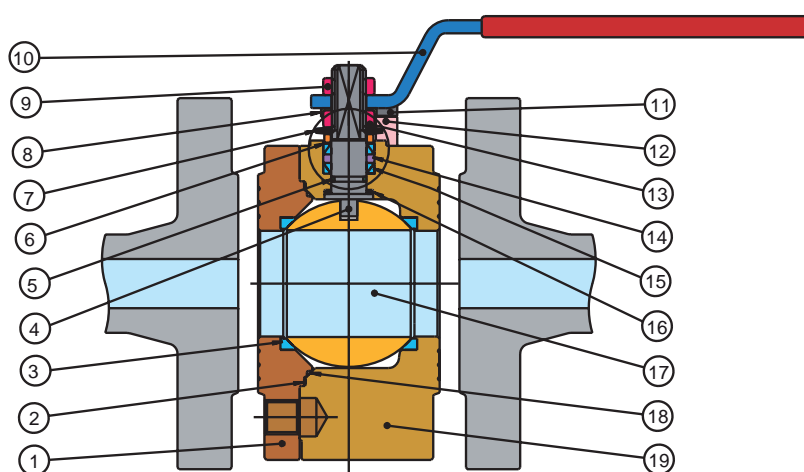

Table 2 Materials of main construction parts

Pos.	Description	Material
1	2. part of body	ASTM A 105
2	Gasket	Grafit
3	Seats	PTFE
4	Stem	AISI 304 (DIN 1.4301)
5	O-ring	FKM
6	Washers	AISI 304 (DIN 1.4301)
7	Spring washer	50 Cr V4
8	Fixing nut	AISI 304 (DIN 1.4301)
9	Locking nut	ASTM A 105
10	Hand lever	ASTM A 105
11	Screw	ASTM A 105
12	Operation - stop	ASTM A 105
13	Retaining ring	ASTM A 105
14	Upper ring	PTFE
15	Packing	PTFE
16	Washer	PTFE
17	Ball	AISI 304 (DIN 1.4301)
18	Gasket	PTFE
19	1. part of body	ASTM A 105

TECHNICAL DRAWING AND DIMENSIONS

Fig. 3 DN15–DN100 JADE type

DN125–DN200 DIAMOND type

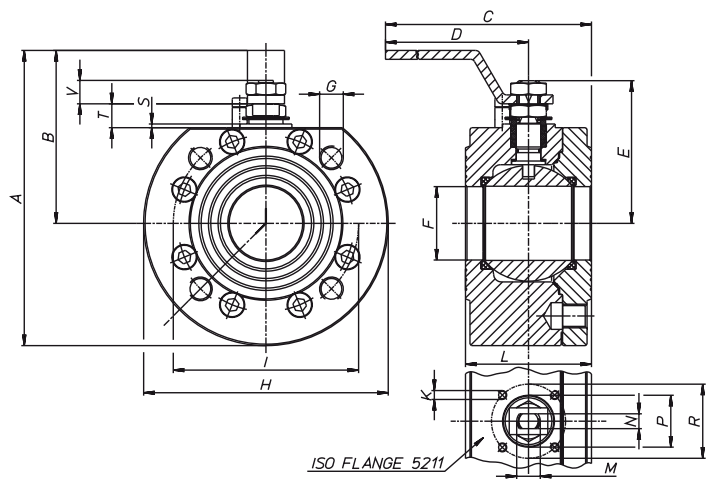
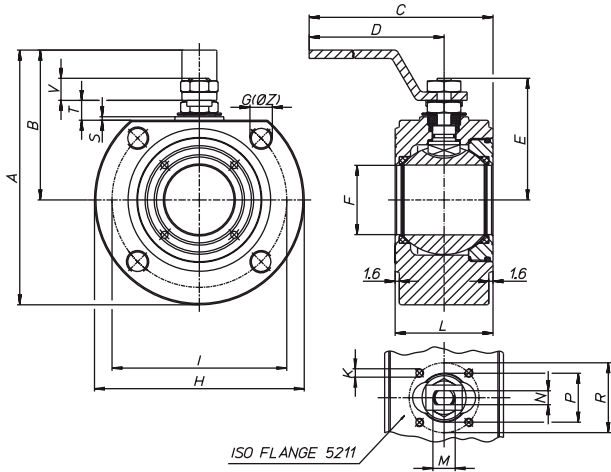
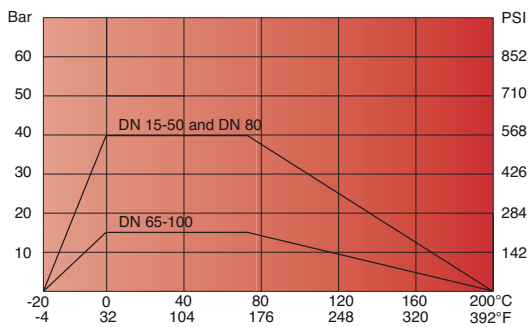

Table 3

K85 171 540/PN40		Dimensions (mm)																		Number of wholes	ISO 5211	kg		
JADE	A	B	C	D	E	F	G	H	K	I	L	M	N	P	R	S	T	V						
DN 15	110	65	160	140	48	15	M12	90	M5	65	35	M10	6	25	36	2	8	9	4	F03	2,4			
DN 20	120	70	160	140	51	20	M12	100	M5	75	38	M10	6	25	36	2	8	9	4	F03	2,9			
DN 25	137	82	200	180	62,5	25	M12	110	M5	85	43	M12	8	30	42	2	11,5	11,5	4	F04	3,5			
DN 32	150	85	200	180	67	32	M16	130	M5	100	54	M12	8	30	42	2	9,5	11,5	4	F04	4,5			
DN 40	172	15	260	230	80	40	M16	150	M6	110	60	M16	10	35	50	2,5	14	16	4	F05	7			
DN 50	185	102	265	230	87	50	M16	165	M6	125	70	M16	10	35	50	2,5	14	16	4	F05	10,5			
DN 65	230	137,5	385	333	122,5	65	M16	185	M8	155	103	M22	1č	55	70	3	18,7	23,8	4	F07	16,5			
DN 80	245	150	395	333	132,5	78	M16	200	M8	160	122	M22	14	55	70	3	18,7	23,8	8	F07	21,5			
DN 100	275	165	447	370	148,5	96	M16	220	M10	180	153	M27	16	70	102	3	22,2	25,3	8	F10	34,5			
DIAMOND																								
DN 125	316	181	455	370	166,5	118	M22	270	M10	220	185	M27	16	70	102	3	22,2	25,3	8	F10	61			
DN 150	396	249	702	584	200	144	M24	295	M12	250	235	M42	26	...	125	...	4	31,5	8	F12	91,9			
DN 200	475	288	739	584	235	192	M27	373	M12	320	310	M42	26	...	125	...	4	27	12	F12	183			

PRESSURE/TEMPERATURE DIAGRAM - JADE



HEAD LOSS DIAGRAM - JADE

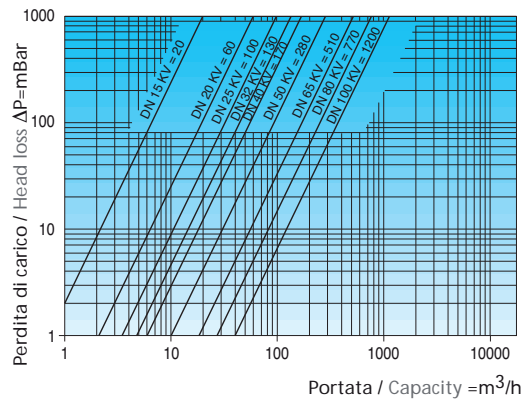

PRESSURE/TEMPERATURE DIAGRAM - DIAMOND

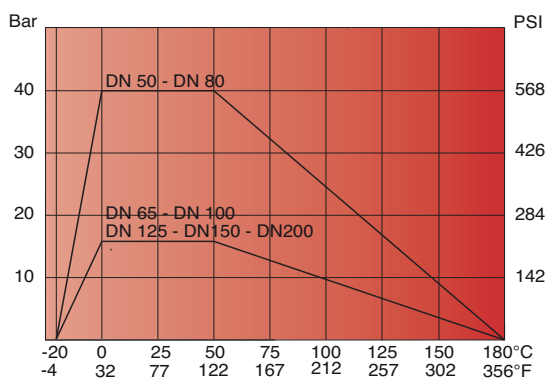

HEAD LOSS DIAGRAM - DIAMOND

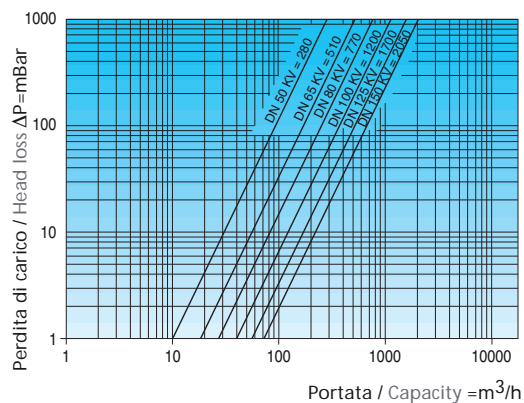

BREAKING TORQUES - JADE/DIAMOND

DN	15	20	25	32	40	50	65	80	100	125	150	200
PN (bar)	Breaking torque (Nm)											
0	4	7	10	16	25	35	55	75	150	240	310	600
16	4,8	8,5	11,3	19	28	39	69	84,5	168	300	400	800
25	5,2	9,1	12	20,5	29,5	41,5	62,5	92	180	450	600	1200
40	6	10,5	13	22,5	31,5	44	67	99	195	475	900	1800

Note:
 For safe operation of valves with pneumatic or electric control, the relevant safety factor must be taken into account when dimensioning the actuator.

The data given in the catalog are informative and the manufacturer reserves the right to make technical changes.