



- design BS 5351
- full bore
- split body, floating ball, PTFE seats
- ISO 5211 top flange
- DN ≥ 25 antistatic device
- fire safe BS 6755, API 6FA, API 607

APPLICATION:

- piping systems for processing, treatment and transport of liquid and gaseous media

ADVANTAGES:

- low weight
- low pressure loss
- space saving construction
- easy installation and maintenance
- reliability
- possibility of automatic operation

TECHNICAL DATA:

Working fluid:	non-aggressive liquids and gases (water, steam, oil, air, fuel gases, oil and oil derivatives) depending on construction materials of valve
Working temperature:	from -10 °C to +180 °C
Max. working pressure:	4 MPa, more in Pressure/Temperature Diagram
Construction materials:	more in table of Materials of main construction parts
Face to face:	acc. to manufacturer
Mounting between flanges acc. to EN 1092-1, B1 / PN 40	

The ball valve is a two-way shut-off valve intended for installation in horizontal or vertical piping. The shut-off element is a ball with a through hole, which rotates through 90° and closes the working fluid flow in the seats. The ball valve is not suitable for abrasive working media and coagulating liquids. It is designed to operate either in the OPEN or CLOSED position.

Operating:	hand wheel
Option:	electric or pneumatic operating antistatic device for DN15–DN20 degreasing service delivery including counter-flanges, sealing and bolting material
Testing:	each ball valve shall be tested in accordance with EN 12266 and supplied with accompanying documentation according to EN 10204
Certification:	PED 2014/68/ EU ATEX 94/9/ CE

DESIGN AND CONSTRUCTION MATERIALS OF BALL VALVE JADE/PN40

Fig. 1 DN 15–DN 100

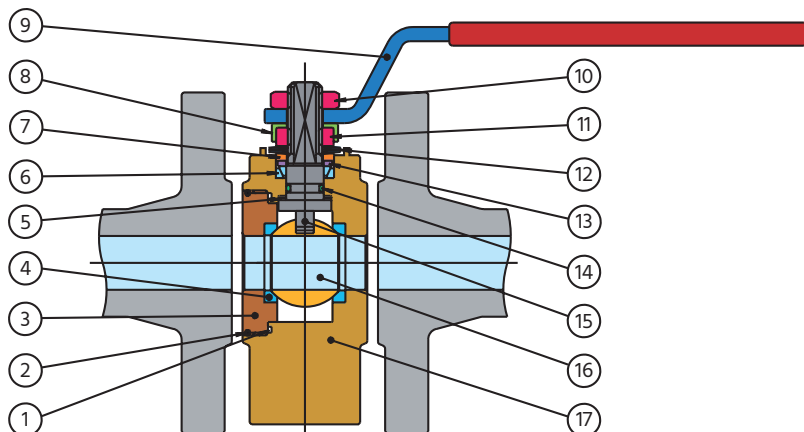

Table 1 Materials of main construction parts

Pos.	Description	Material	Material
1	Gasket		PTFE
2	O-ring		NBR
3	2. part of body		ASTM A 105
4	Seats		PTFE
5	Washer		PTFE
6	Packing		PTFE
7	Operation- stop		AISI 304 (DIN 1.4301)
8	Fixing nut		AISI 304 (DIN 1.4301)
9	Hand lever		Fe P02 zinc.
10	Locking nut		steel galvanized
11	Retaining ring		steel galvanized
12	Spring washer		50 Cr V4
13	Thrust washers		AISI 304 (DIN 1.4301)
14	O-ring		FKM
15	Stem		AISI 304 (DIN 1.4301)
16	Ball DN		DN 15/40 AISI 316 (DIN 1.4401) DN 50/100 AISI 304 (DIN 1.4301)
17	1. part of body		ASTM A 105

TECHNICAL DRAWING AND DIMENSIONS OF BALL VALVE JADE/PN40

Fig. 2 DN 15–DN 100

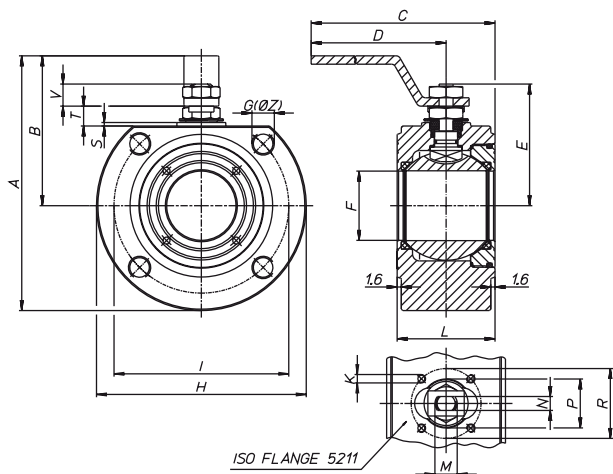
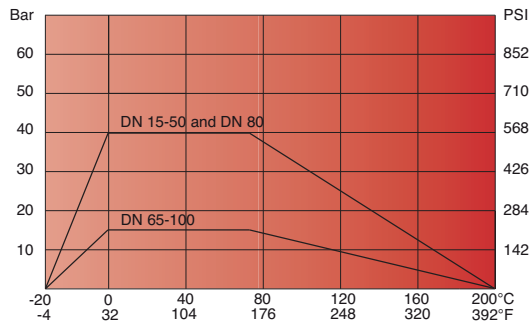

Table 2

JADE/PN40	Rozměry (mm)																		počet otvorů	ISO 5211	kg
	A	B	C	D	E	F	G	H	K	I	L	M	N	P	R	S	T	V			
DN 15	110	65	160	140	48	15	M12	90	M5	65	35	M10	6	25	36	2	8	9	4	F03	1,35
DN 20	120	70	160	140	51	20	M12	100	M5	75	38	M10	6	25	36	2	8	9	4	F03	1,81
DN 25	137	82	200	180	62,5	25	M12	110	M5	85	43	M12	8	30	42	2	11,5	11,5	4	F04	2,51
DN 32	150	85	200	180	67	32	M16	130	M5	100	54	M12	8	30	42	2	9,5	11,5	4	F04	4,33
DN 40	172	15	260	230	80	40	M16	150	M6	110	60	M16	10	35	50	2,5	14	16	4	F05	5,55
DN 50	185	102	265	230	87	50	M16	165	M6	125	70	M16	10	35	50	2,5	14	16	4	F05	7,30
DN 65	230	137,5	385	333	122,5	65	M16	175	M8	155	103	M22	1č	55	70	3	18,7	23,8	4	F07	15,00
DN 80	245	150	395	333	132,5	78	M16	200	M8	160	122	M22	14	55	70	3	18,7	23,8	8	F07	20,67
DN 100	275	165	447	370	148,5	96	M16	235	M10	180	140	M27	16	70	102	3	22,2	25,3	8	F10	31,50

PRESSURE/TEMPERATURE DIAGRAM



HEAD LOSS DIAGRAM

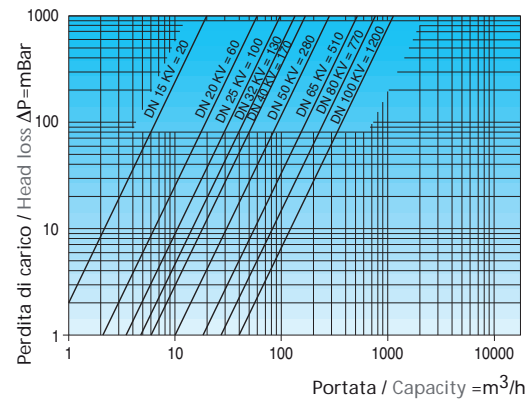

BREAKING TORQUES

DN	15	20	25	32	40	50	65	80	100
PN (bar)									
0	4	7	10	16	25	35	55	75	150
16	4,8	8,5	11,3	19	28	39	69	84,5	168
25	5,2	9,1	12	20,5	29,5	41,5	62,5	92	180
40	6	10,5	13	22,5	31,5	44	67	99	195

Note:

For safe operation of valves with pneumatic or electric control, the relevant safety factor must be taken into account when dimensioning the actuator.

TECHNICAL DRAWING AND DIMENSIONS OF JADE/PN40
WITH DOUBLE-ACTING PNEUMATIC ACTUATOR

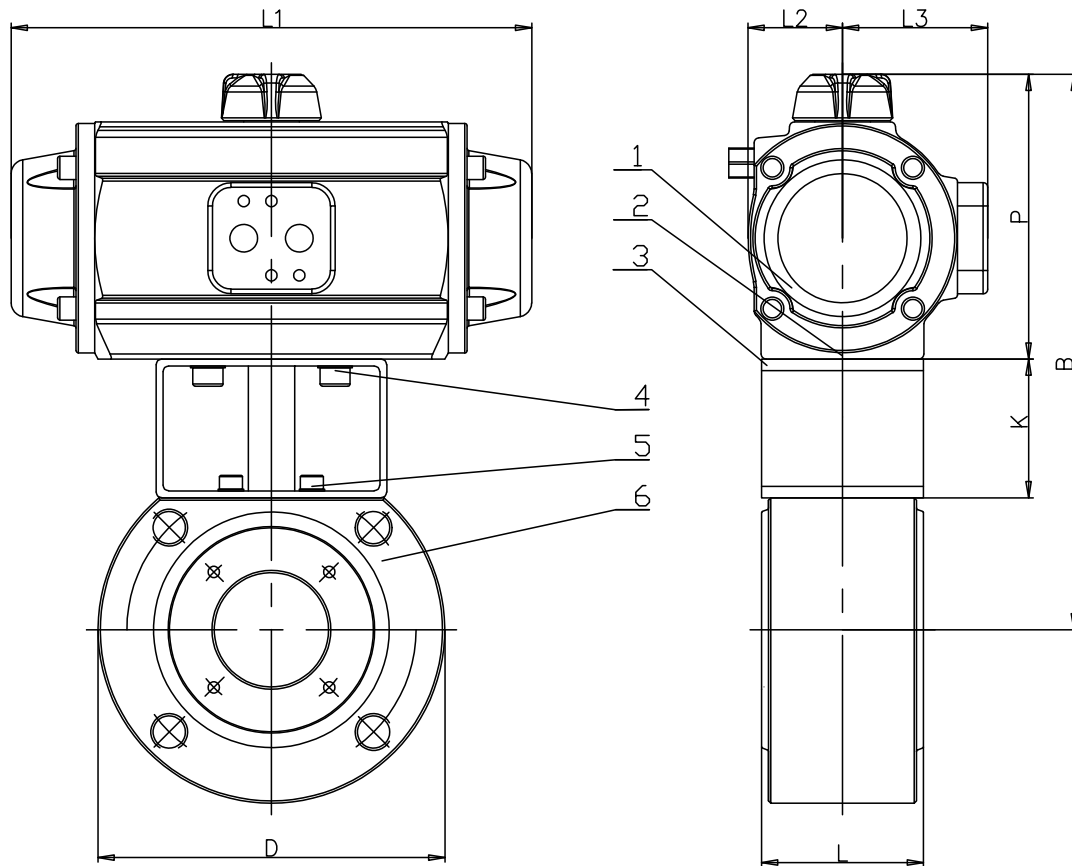

1	Dvojčinný pneumatický pohon / Double acting pneumatic actuator										
2	Vložka / Connection										
3	Montážní sada / Mounting Kit										
4	Šrouby / Bolts A										
5	Šrouby / Bolts B										
6	Kulový kohout / Ball valve JADE										
Kohout kulový mezipřírubový s dvojčinným pneumatickým pohonem JADE PN40											
Wafer ball valve with doubleacting pneumatic actuator JADE PN40											
DN	PN40	Pohon / Actuator	D	L	K	P	L1	L2	L3	B	Kg
15	40	PAW	90	35	60	89	141	28	48	180	3
20	40	PAW	100	38	60	89	141	28	48	183	3,7
25	40	PA00	110	43	60	102	155	32	52	202	4,8
32	40	PA05	130	54	60	119	201	40	62	225	8
40	40	PA05	150	60	60	119	201	40	62	229	9,3
50	40	PA10	165	70	60	123	226	41	63	240	11,5
65	40	PA15	175	95	60	139	265	48	71	279	21
80	40	PA20	200	122	60	147	312	52	75	297	29
100	40	PA25	235	140	80	175	358	64	89	356	49

TECHNICAL DRAWING AND DIMENSIONS OF JADE/PN40
WITH SINGLE-ACTING PNEUMATIC ACTUATOR

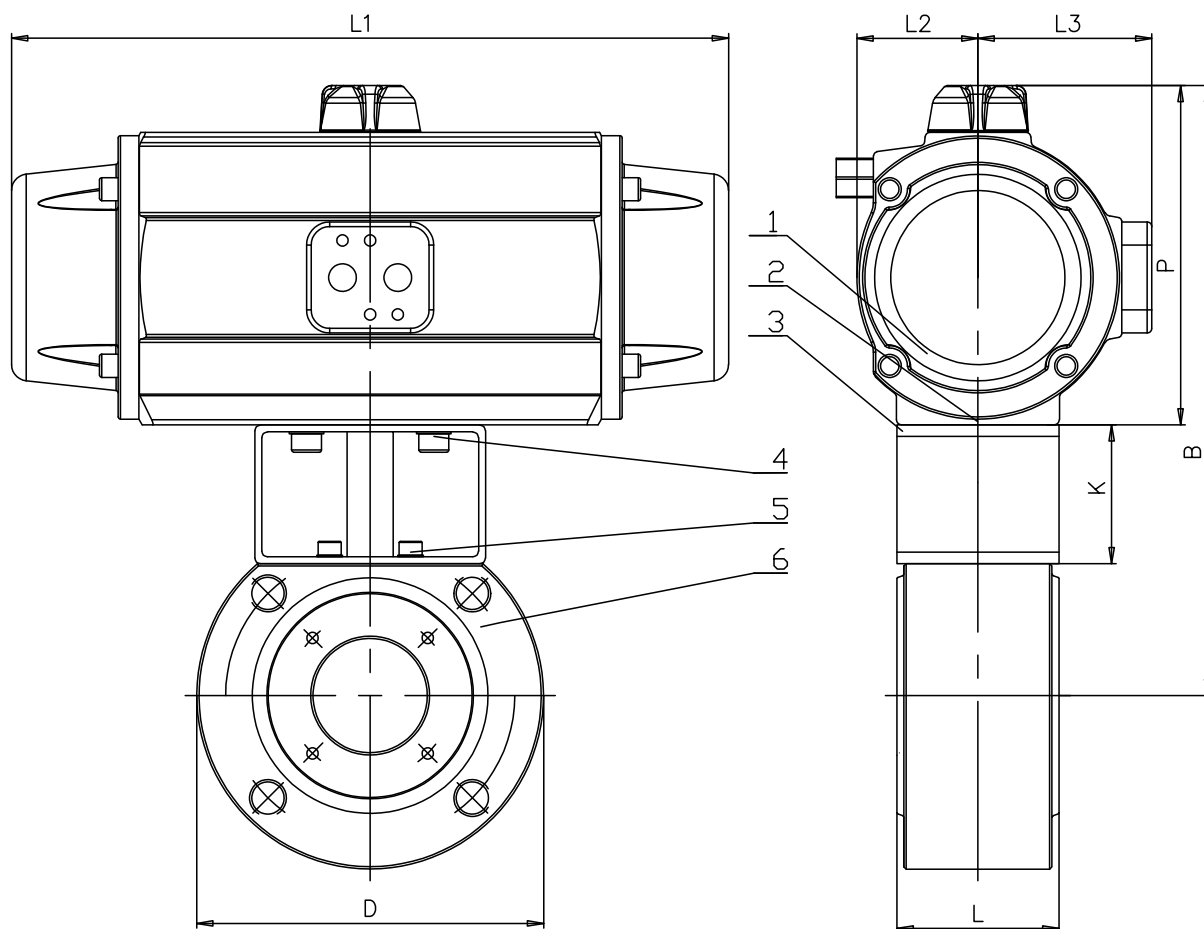

1	Jednočinný pneumatický pohon / Single acting pneumatic actuator										
2	Vložka / Connection										
3	Montážní sada / Mounting Kit										
4	Šrouby / Bolts A										
5	Šrouby / Bolts B										
6	Kulový kohout / Ball valve JADE										
Kohout kulový mezipřírubový s jednočinným pneumatickým pohonem JADE PN40											
Wafer ball valve with single acting pneumatic actuator JADE PN40											
DN	PN40	Pohon / Actuator	D	L	K	P	L1	L2	L3	B	Kg
15	40	PA00S	90	35	60	102	155	32	52	193	3,9
20	40	PA05S	100	38	60	119	201	40	62	213	5,6
25	40	PA05S	110	43	60	119	201	40	62	219	6,7
32	40	PA15S	130	54	60	139	265	48	71	245	10,8
40	40	PA15S	150	60	60	139	265	48	71	249	11,9
50	40	PA20S	165	70	60	147	312	52	75	264	15,1
65	40	PA25S	175	95	80	175	358	64	89	335	28,7
80	40	PA30S	200	122	80	191	429	72	97	361	39
100	40	P40S	235	140	80	272	598	106	120	453	76

The data given in the catalog are informative and the manufacturer reserves the right to make technical changes.