

TYPE C

125 × 125 ÷ 1 400 × 1 400

KNIFE GATE VALVE WITH SQUARE CROSS-SECTION



- welded body with square flow and square flanges
- metal or soft seat with tightness from one side
- rising stem
- wide range of material variants of seats
- low control torque

AREAS OF APPLICATION:

- transport and storage of bulk materials
- mining industry
- chemical industry

ADVANTAGES OF USE:

- low pressure drop
- low weight
- easy installation under hoppers (silos)
- low maintenance costs
- long life



SPECIFICATIONS:

Working medium:	dry media (powders, granules) or liquid media with high concentration of solid particles, depending on the construction materials of the knife gate valve
Maximum working pressure:	0.6 kg/cm ²
Maximum temperature range:	depends on the design and construction materials of knife gate valve, working medium and working conditions

Types of seats and their tightness:

Pic. 1

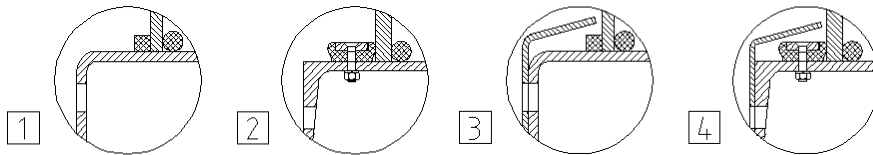

Seat Type		Tightness (%)
1	metal-metal (metal)	98.8
2	metal-elastomer	100
3	metal-metal with deflector to protect the body from abrasion	98.8
4	metal-elastomer with deflector to protect the body from abrasion	100

Please contact our sales department in order to select the appropriate type of seat and suitable material of body, knife, seat and packing.

Face to face and flange drilling: according to manufacturer - see further in the datasheet

Operating: hand wheel as standard

Other options:

- gear with handwheel
- non-rising stem
- extended stem
- chain wheel
- electric, pneumatic or hydraulic actuator
- limit switches
- locking device
- with rectangular cross-section
- with holes in the body for air or steam cleaning
- different type and color of the protective coating

Testing: each knife gate valve is tested according to EN 12266-1 and supplied with accompanying documentation according to EN 10204

Certification: PED 2014/68 / EU
ATEX (II, 2 and 22 GD) 94/9 / EC

Pic. 2

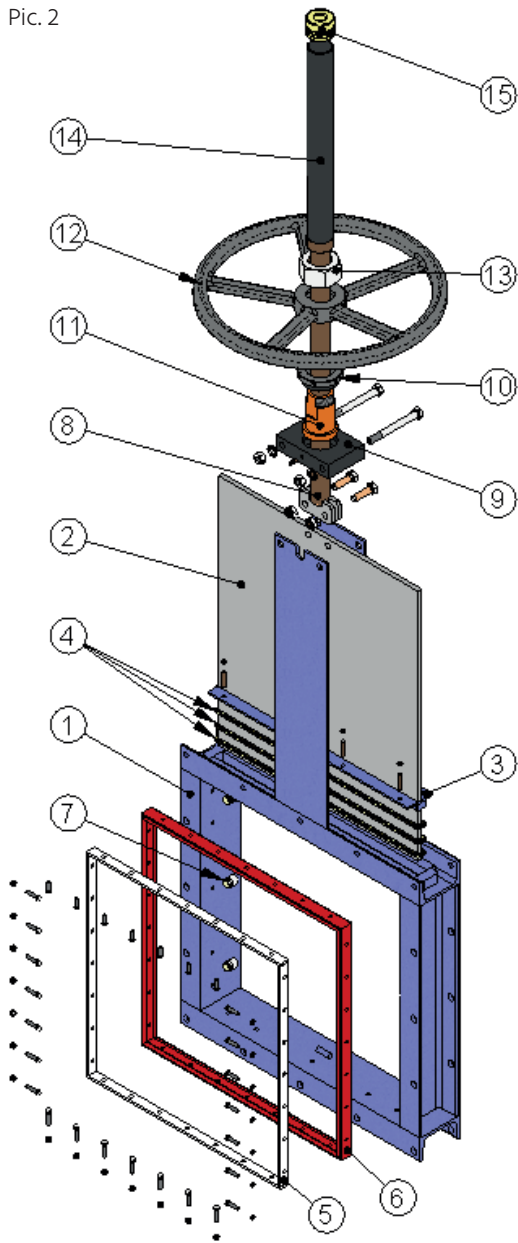

Position	Description	Basic material variants of gate valves with soft seat	
1	Body	S275 JR *)	AISI 304/AISI 316
2	Knife	AISI 304	AISI 304/ AISI 316
3	Packing gland	S275 JR *)	AISI 304/AISI 316
4	Packing	Synt. + PTFE	
5	Gasket	AISI 304	
6	Seat	EPDM	
7	Guide	PTFE	
8	Stem	AISI 303	
9	Bracket	Steel	
10	Nut	Steel	
11	Stem nut	bronze	
12	Hand wheel	GJS-500	
13	Nut	5.6 zinc plated	
14	Stem protection	Steel	
15	Top cap	plastic	

*) With epoxy protective coating 80 µm, RAL 5015

DIMENSIONS

Type C with handwheel

Pic. 3

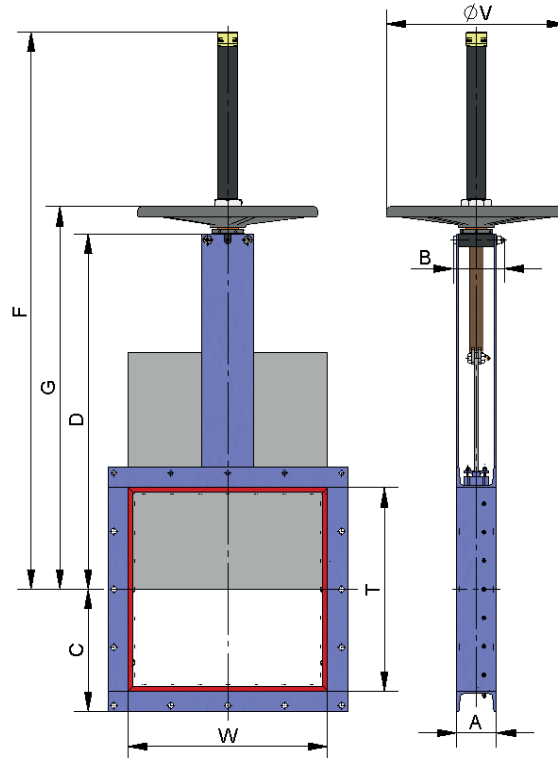

width × height	ΔP (Kg/cm ²)	A	B	C	D	F	G	ØV
125×125	0,6	80	102	107,5	281,5	496	317	225
150×150	0,6	80	102	120	319	534	354	225
200×200	0,6	80	102	145	394	650	429	225
250×250	0,6	80	111	170	471	802	524	225
300×300	0,6	80	111	195	546	935	599	325
350×350	0,6	100	116	225	621	1060	674	325
400×400	0,6	100	116	250	697	1185	749	325
450×450	0,6	100	128	275	785	1338	852	325
500×500	0,6	100	128	300	864	1465	929	450
550×550	0,6	100	128	325	939	1590	1004	450
600×600	0,6	100	128	350	1014	1715	1079	450
650×650	0,6	100	128	375	1089	1840	1154	450
700×700	0,6	120	148	405	1178	1981	1245	450
750×750	0,6	120	148	430	1253	2106	1320	450
800×800	0,6	120	148	455	1328	2231	1395	450
900×900	0,6	140	168	510	1478	2481	1545	450
1200×1200	0,6	160	186	665	1929	3280	2040	-

Note: 1200 × 1200 with gear and handwheel.

Type C with gear

Pic. 4

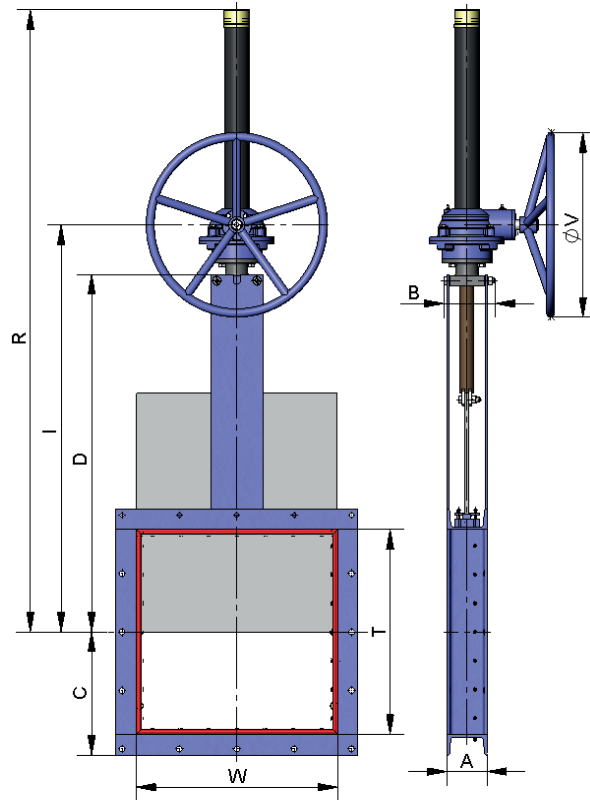

width × height	ΔP (Kg/cm ²)	A	B	C	D	I	R	ØV
125×125	0,6	80	102	107,5	281,5	401	556	300
150×150	0,6	80	102	120	319	439	619	300
200×200	0,6	80	102	145	394	514	744	300
250×250	0,6	80	111	170	471	589	869	300
300×300	0,6	80	111	195	546	667	994	300
350×350	0,6	100	116	225	621	744	1124	300
400×400	0,6	100	116	250	697	819	1249	300
450×450	0,6	100	128	275	785	904	1384	450
500×500	0,6	100	128	300	864	981	1511	450
550×550	0,6	100	128	325	939	1056	1636	450
600×600	0,6	100	128	350	1014	1131	1761	450
650×650	0,6	100	128	375	1089	1206	1886	450
700×700	0,6	120	148	405	1178	1297	2027	450
750×750	0,6	120	148	430	1253	1372	2152	450
800×800	0,6	120	148	455	1328	1447	2277	450
900×900	0,6	140	168	510	1478	1597	2527	450
1000×1000	0,6	140	168	665	1628	1747	2777	450
1200×1200	0,6	160	186	613	1929	2011	3251	650
1400×1400	0,6	160	218	670	2229	2311	3751	650

Type C with chain wheel

Pic. 6

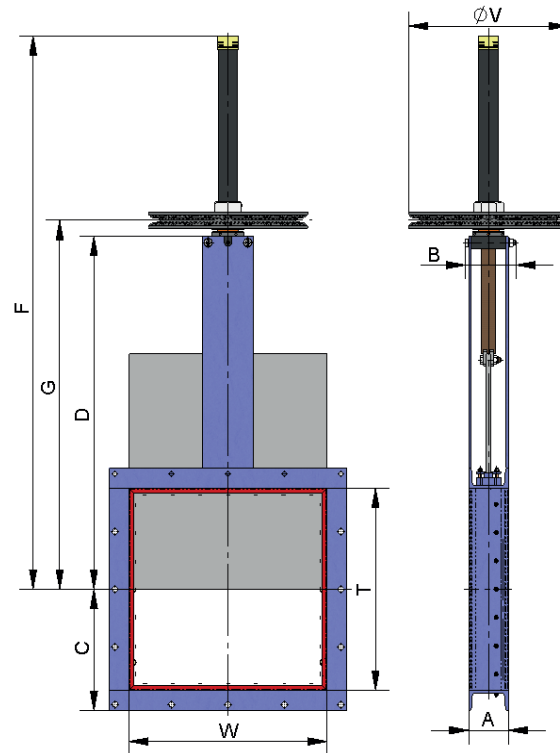

width × height	ΔP (Kg/cm ²)	A	B	C	D	F	G	ØV
125×125	0,6	80	102	107,5	281,5	496	317	225
150×150	0,6	80	102	120	319	534	354	225
200×200	0,6	80	102	145	394	650	429	225
250×250	0,6	80	111	170	471	802	524	300
300×300	0,6	80	111	195	546	935	599	300
350×350	0,6	100	116	225	621	1060	674	300
400×400	0,6	100	116	250	697	1185	749	300
450×450	0,6	100	128	275	785	1338	852	402
500×500	0,6	100	128	300	864	1465	929	402
550×550	0,6	100	128	325	939	1590	1004	402
600×600	0,6	100	128	350	1014	1715	1079	402
650×650	0,6	100	128	375	1089	1840	1154	402
700×700	0,6	120	148	405	1178	1981	1245	402
750×750	0,6	120	148	430	1253	2106	1320	402
800×800	0,6	120	148	455	1328	2231	1395	402
900×900	0,6	140	168	510	1478	2481	1545	402
1000×1000	0,6	140	168	560	1628	2746	1695	402
1200×1200	0,6	160	186	665	1929	3280	2040	402
1400×1400	0,6	160	218	765	2229	3760	2340	402

Note: 1000 × 1000 to 1400 × 1400 with gear and chain wheel

Type C with double-acting pneumatic actuator

Pic. 7

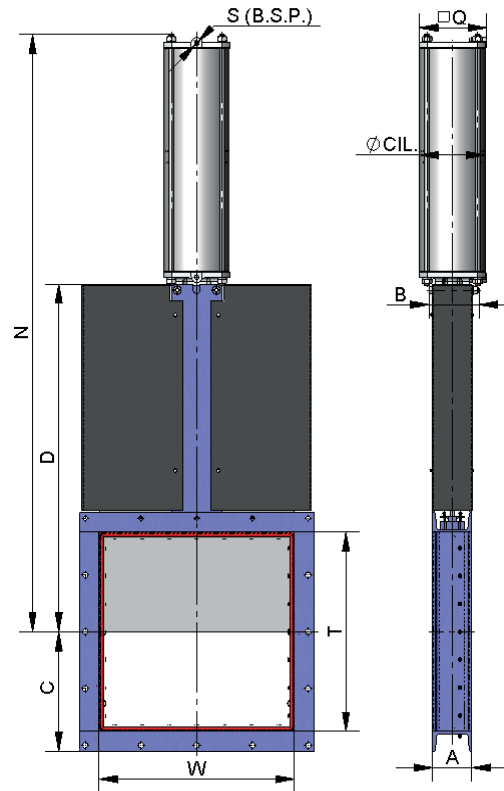

width × height	ΔP (Kg/cm ²)	axial force (N)	A	B	C	D	N	Q	Ø cylinder	Ø piston rods	S (B.S.P.)
125×125	0,6	471	80	102	107,5	281,5	511	90	80	20	1/4"
150×150	0,6	656	80	102	120	319	574	90	80	20	1/4"
200×200	0,6	1115	80	102	145	394	699	90	80	20	1/4"
250×250	0,6	1694	80	111	170	471	824	90	80	20	1/4"
300×300	0,6	2394	80	111	195	546	949	90	80	20	1/4"
350×350	0,6	3340	100	116	225	621	1074	110	100	20	1/4"
400×400	0,6	4319	100	116	250	697	1215	135	125	25	1/4"
450×450	0,6	5424	100	128	275	785	1351	135	125	25	1/4"
500×500	0,6	6654	100	128	300	864	1486	170	160	30	1/4"
550×550	0,6	8010	100	128	325	939	1611	170	160	30	1/4"
600×600	0,6	9491	100	128	350	1014	1736	170	160	30	1/4"
650×650	0,6	11098	100	128	375	1089	1861	170	160	30	1/4"
700×700	0,6	12830	120	148	405	1178	2014	215	200	30	3/8"
750×750	0,6	14688	120	148	430	1253	2182	270	250	40	3/8"
800×800	0,6	17005	120	148	455	1328	2307	270	250	40	3/8"
900×900	0,6	21436	140	168	510	1478	2560	270	250	40	3/8"
1000×1000	0,6	27160	140	168	560	1628	2815	382	300	45	1/2"
1200×1200	0,6	38928	160	186	665	1929	3310	426	350	45	1/2"
1400×1400	0,6	52808	160	218	765	2229	3877	508	400	50	1/2"

Note: control air pressure of a standard pneumatic actuator is in the range of 6–10 kg / cm². Contact our sales department to design a suitable pneumatic actuator if the control air pressure is less than 6 bar.

Type C with single-acting pneumatic actuator

Pic. 8

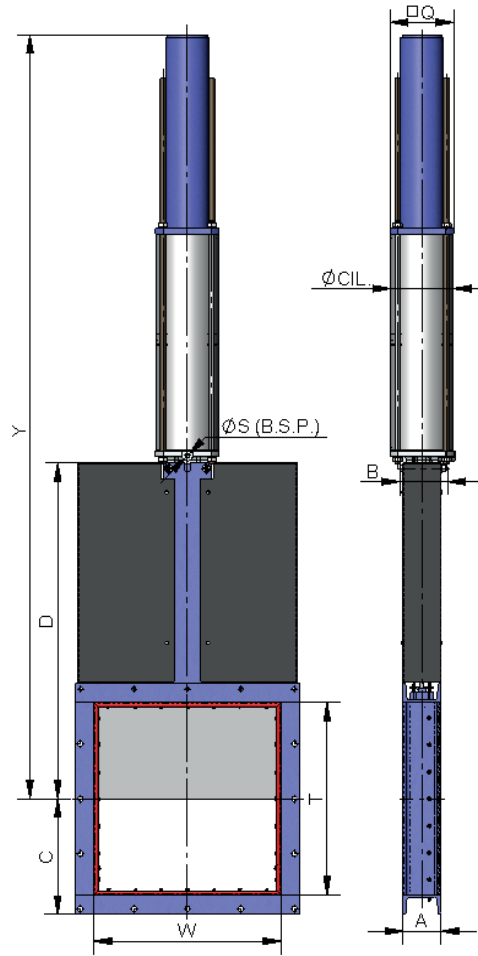

width × height	ΔP (Kg/cm ²)	axial force (N)	A	B	C	D	Y	Ø J	Ø cylinder	Ø piston rods	S (B.S.P.)
125×125	0,6	471	80	102	107,5	281,5	816	135	125	25	1/4"
150×150	0,6	656	80	102	120	319	861	135	125	25	1/4"
200×200	0,6	1115	80	102	145	394	939	135	125	25	1/4"
250×250	0,6	1694	80	111	170	471	1130	135	125	25	1/4"
300×300	0,6	2394	80	111	195	546	1255	135	160	30	1/4"

Note: control air pressure of a standard pneumatic actuator is in the range of 6–10 kg/cm². Contact our sales department to design a suitable pneumatic actuator if the control air pressure is less than 6 bar.

DIMENSIONS FOR INSTALLATION BETWEEN FLANGES

width × height	ΔP (Kg/cm ²)	Flange drilling						
		○	●	M screw	P	Ød	U×V	N° div. × Y = Z
125×125	0,6	5	3	M 10	8	12	215×215	2 × 92,5 = 185
150×150	0,6	5	3	M 10	8	12	240×240	2 × 105 = 210
200×200	0,6	5	3	M 10	8	12	290×290	2 × 130 = 260
250×250	0,6	5	3	M 10	8	12	340×340	2 × 155 = 310
300×300	0,6	8	4	M 10	8	12	390×390	3 × 120 = 360
350×350	0,6	8	4	M 12	8,5	14	450×450	3 × 140 = 420
400×400	0,6	11	5	M 12	8,5	14	500×500	4 × 117,5 = 470
450×450	0,6	11	5	M 12	8,5	14	550×550	4 × 130 = 520
500×500	0,6	11	5	M 12	8,5	14	600×600	4 × 142,5 = 570
550×550	0,6	11	5	M 12	8,5	14	650×650	4 × 155 = 620
600×600	0,6	11	5	M 12	8,5	14	700×700	4 × 167,5 = 670
650×650	0,6	11	5	M 12	8,5	14	750×750	4 × 180 = 720
700×700	0,6	14	6	M 12	9	14	810×810	5 × 155 = 775
750×750	0,6	14	6	M 12	9	14	860×860	5 × 166 = 830
800×800	0,6	14	6	M 12	9	14	910×910	5 × 175 = 875
900×900	0,6	17	7	M 12	10	14	1020×1020	6 × 162,5 = 975
1000×1000	0,6	20	8	M 12	10	14	1120×1120	7 × 155 = 1085
1200×1200	0,6	20	8	M 12	10,5	14	1320×1320	7 × 184,5 = 1291,5
1400×1400	0,6	20	8	M 12	10,5	14	1520×1520	7 × 213 = 1491

Pic. 9

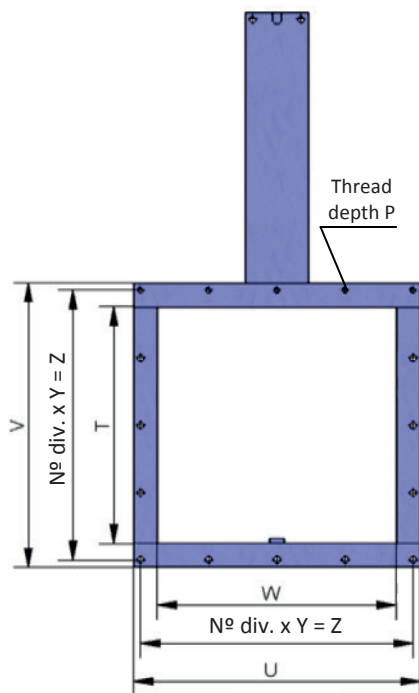

- through holes
- blind holes

The information given in the catalog is informative and the supplier reserves the right to make technical changes.