

Kulové kohouty přírubové s 2dílným tělesem, plovoucí koulí a plným průtokem

2-PC ball valves, flanged type, with floating ball and full bore

KV-L6N / PN40, DN15 ÷ DN100

KV-L6K / PN16, DN65 ÷ DN200



KONSTRUKČNÍ PROVEDENÍ:

- dle EN12516-1
- plný průtok
- dvoudílné těleso, plovoucí koule, TFM 1600 sedla
- vrchní příruba pro přímou montáž ovládání dle ISO5211
- uzamykatelné provedení
- provedení vřetene zabraňuje jeho vystřelení při případném přetlakování
- vyrovnávací otvor zabraňující koncentraci tlaku v prostoru mezi koulí a tělesem
- požární bezpečnost dle: API 607 5th 2005, ISO10497
- antistatické provedení (koule - vřeteno - těleso)
- stavební délka dle EN558-1, řada 27 (DIN 3202 F4: DN15-DN100, DIN3202 F5: DN125-DN200)
- příruby dle EN1092-1
- zkoušeno dle EN12266-1 P10, P11, P12 těsnost A (voda, vzduch)
- výroba odlitků v souladu s technickým předpisem TUV AD 2000-Merkblatt W0

CERTIFIKACE:

- PED 2014/68/EU
- NACE MR-0175
- TA-Luft/ISO15848-1

DESIGN:

- according to EN12516-1
- full bore
- 2-PC body, floating ball, TFM 1600 seats
- ISO5211 top flange for direct mounting of operating
- locking device
- spindle protected against firing in case of overpressure
- compensating hole preventing of concentration of pressure in the space between ball and body
- fire safe acc. to API 607 5th 2005, ISO10497
- antistatic (ball - spindle - body)
- face to face acc. to EN558-1, serie 27 (DIN 3202 F4: DN15-DN100, DIN3202 F5: DN125-DN200)
- flanges acc. to EN1092-1
- testing according to EN12266-1 P10, P11, P12 tightness A (water, air)
- production of castings in accordance with technical regulation TUV AD 2000-Merkblatt W0

CERTIFICATION:

- PED 2014/68/EU
- NACE MR-0175
- TA-Luft/ISO15848-1

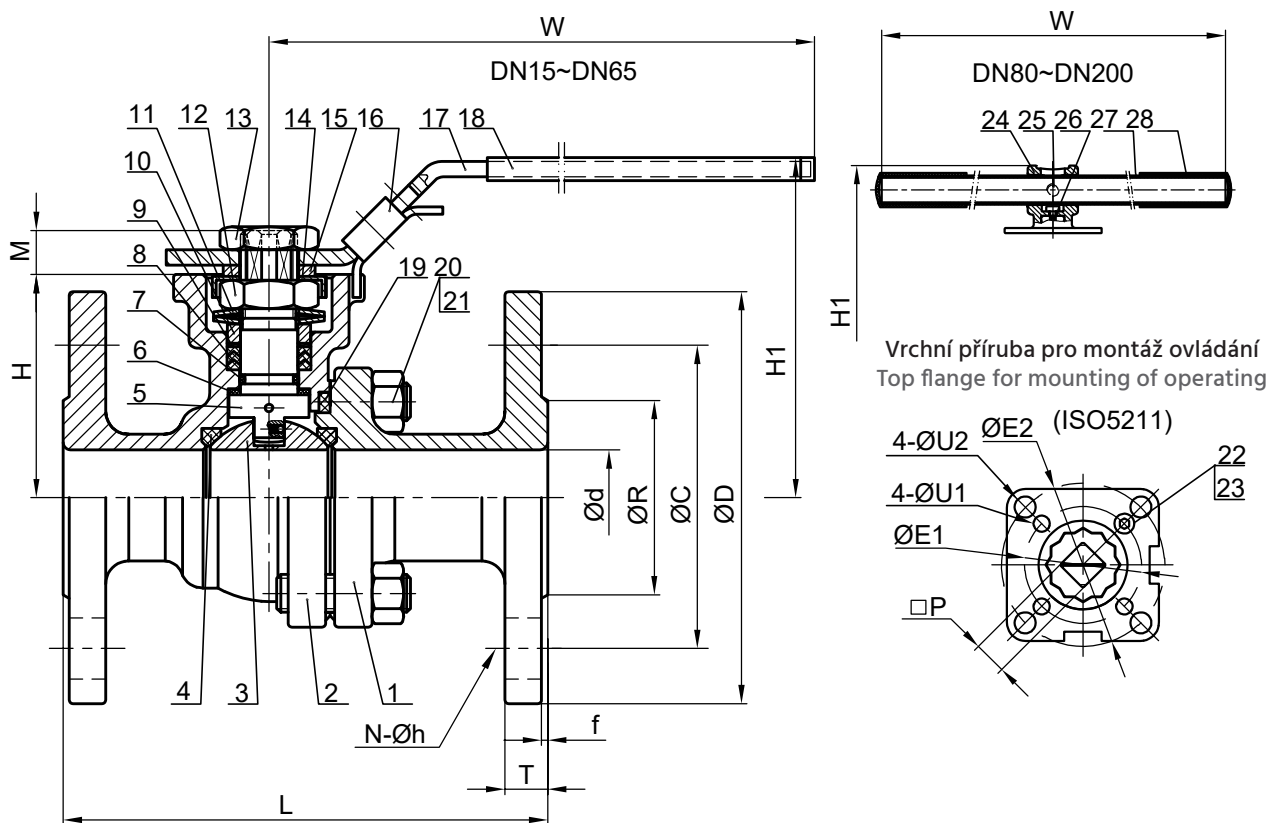

ZÁKLADNÍ ROZMĚRY A HMOTNOST / GENERAL DIMENSIONS AND WEIGHT

Rozměry jsou uvedeny v mm.
Dimensions are in mm.

DN	PN	d	L	R	D	C	f	T	N	h	H	H1	W	P	M	E1	E2	U1	U2	ISO5211	kg
15		15	115	45	95	65	2	16	4	14	48	78	147	9	8	36	42	6	6	F03~F04	2,37
20		20	120	58	105	75	2	18	4	14	53	84	147	9	9	36	42	6	6	F03~F04	3,15
25	10/16	25	125	68	115	85	2	18	4	14	59	90	177	11	11	42	50	6	7	F04~F05	4,09
32	25/40	32	130	78	140	100	2	18	4	18	71	102	177	11	11	42	50	6	7	F04~F05	5,56
40		38	140	88	150	110	3	18	4	18	76	110	197	14	14	50	70	7	9	F05~F07	6,98
50		50	150	102	165	125	3	20	4	18	85	118	197	14	14	50	70	7	9	F05~F07	9,67
65	10/16	63,5	170	122	185	145	3	18	4	18	102	150	267	17	17	70	102	9	11	F07~F10	13,90
	22							8	18	107	155	14,60									
80	10/16	76,0	180	138	200	160	3	20	8	18	112	176	300	17	17	70	102	9	11	F07~F10	18,10
	24							8	18	117	181	20,40									
100	10/16	100	190	158	220	180	3	20	8	18	140	211	400	22	22	-	102	-	11	F10	25,30
	162			235	190	24		8	22	140	211	29,50									
125	10/16	125	325	188	250	210	3	22	8	18	183	263	600	27	27	125	-	14	-	F12	51,00
	270			220	26	8		26	183	263	59,50										
150	10/16	150	350	212	285	240	3	22	8	22	204	284	800	27	27	125	-	14	-	F12	72,50
	218			300	250	28		8	26	204	284	84,50									
200	16	200	400	268	340	295	3	24	8	22	253	334	800	27	27	125	140	14	18	F12	120,00
	285			375	320	34		12	30	253	334	151,00									

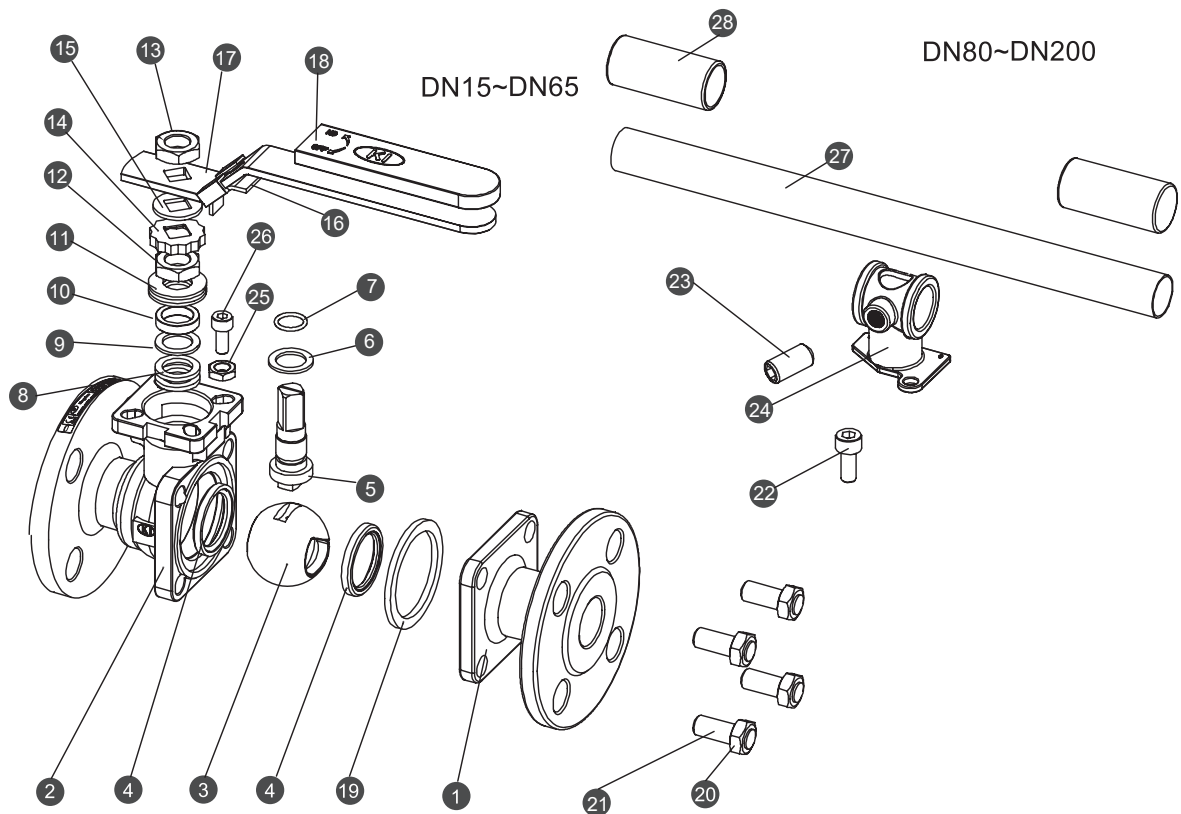

KONSTRUKCE A KONSTRUKČNÍ MATERIÁLY / CONSTRUCTION AND MATERIALS

Pozice Pos.	Název součásti Component name	Materiál Material	Pozice Pos.	Název součásti Component name	Materiál Material
1	Příruba tělesa / Body flange	1.4408 1.0619	15	Podložka páky / Washer	304
2	Těleso / Body	1.4408 1.0619	16	Uzamyk. zařízení / Locking device (DN15~DN65)	304
3	Koule / Ball	CF8M/F316	17	Páka / Hand lever (DN15~DN65)	304
4	Sedla / Seats	TFM1600	18	Kryt páky / Cover of lever (DN15~DN65)	VINYL
5	Vřetenlo / Spindle	316 304	19	Těsnění tělesa / Body seal	316 Spirál.vinuté+Grafit / Spiral wound+Graphit
6	Axiální kluzná podložka / Axial sliding washer	PTFE	20	Matice / Nut	A2-70 8
7	O-koružek / O-ring	FKM	21	Šrouby / Screws	A2-70 8.8
8	Ucpávkové těsnění / Packing	Grafit	22	Šroub dorazu / Stop screw	A2-70
9	Vymezovací kroužek / Spacer ring	304	23	Matice dorazu / Stop nut	A2-70
10	Ucpávkové pouzdro / Packing case	316	24	Adaptér páky / Adapter of lever (DN80~DN200)	CF8
11	Talířová pružina / Disc spring	301	25	Matice / Matice	A2-70
12	Vřetenová matice / Spindle nut	A194-8	26	Šroub / Screw	A2-70
13	Matice páky / Nut of lever	A194-8	27	Trubka páky / Lever pipe (DN80~DN200)	A53+Zn
14	Pojistná podložka / Lock washer	304	28	Kryt páky / Cover of lever (DN80~DN200)	Vinyl

PRŮTOKOVÝ SOUČINITEL Cv, Kv / FLOW COEFFICIENT Cv, Kv

DN	Cv [US gal.mm-1]	Kv [m³.h-1]
15	18	15,57
20	36	31,14
25	48	41,52
32	93	80,45
40	165	142,73
50	207	179,06
65	450	389,25
80	780	674,70
100	1360	1176,40
125	1700	1470,50
150	2600	2249,00
200	4200	3633,00

ZÁVISLOST OVLÁDACÍHO KROUTÍČÍHO MOMENTU NA TLAKOVÉ DIFERENCI ΔP DEPENDENCE OF TORQUE ON PRESSURE DIFFERENCE ΔP

DN	ΔP_1		ΔP_2		ΔP_3		ΔP_4	
	5 bar	75 psi	10 bar	150 psi	16 bar	300 psi	40 bar	600 psi
	[Nm]	[lb _r -in]	[Nm]	[lb _r -in]	[Nm]	[lb _r -in]	[Nm]	[lb _r -in]
15	5	44	5	5	5	44	5	44
20	6	53	6	6	6	53	6	53
25	10	88	10	10	11	97	11	97
32	13	115	13	13	15	133	17	150
40	19	168	19	19	22	195	24	212
50	25	221	29	29	32	283	34	301
65	40	354	45	45	49	434	52	460
80	65	575	72	72	81	717	88	779
100	100	885	110	110	122	1080	132	1168
125	190	1681	210	210	245	2168	280	2478
150	280	2478	306	306	340	3009	510	4514
200	370	3274	430	430	487	4310	730	6461

Pro dimenzování pohonu je nutné počítat s bezpečnostním faktorem (doporučeno min. 30%).
For design of an actuator it is necessary to take into account the safety factor (recommended min. 30%).

TLAKO-TEPLOTNÍ ZÁVISLOST / PRESSURE-TEMPERATURE DIAGRAM

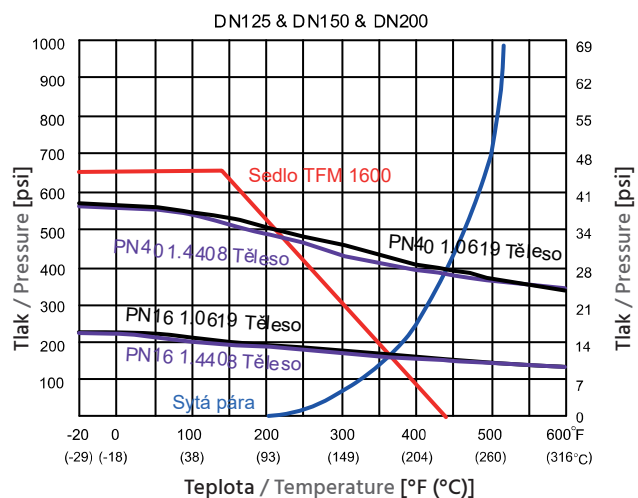
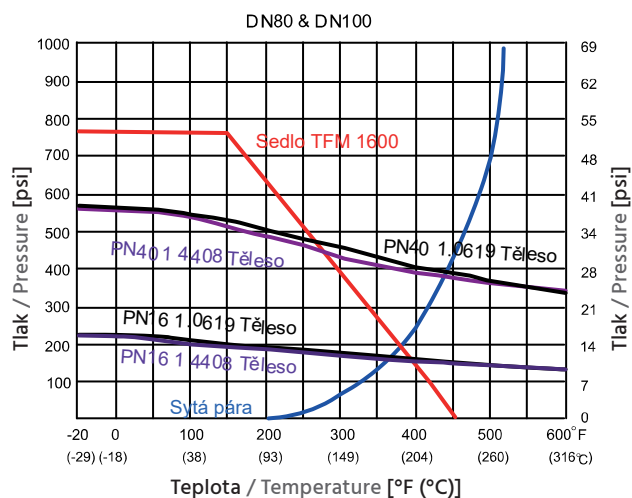
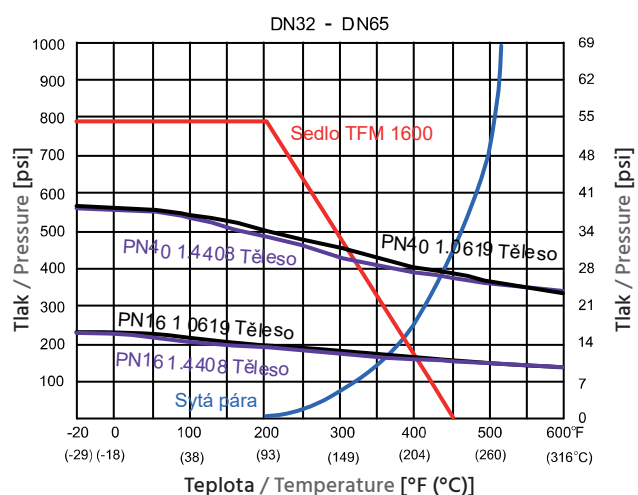
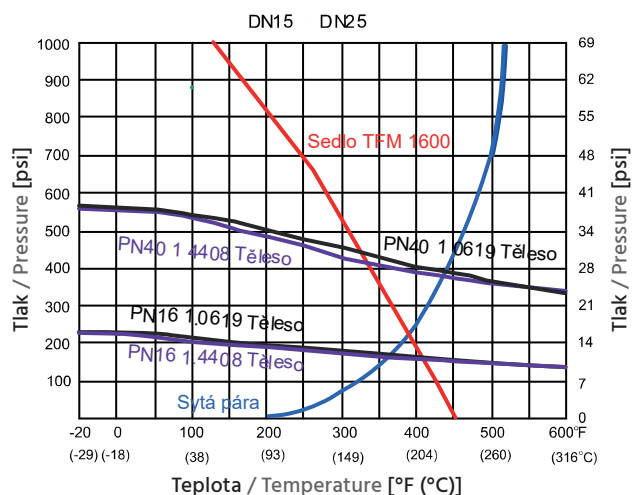

Sedlo = Seat
Těleso = Body
Sytá pára = Saturated steam

KULOVÝ KOHOUT KV-L6N / PN40 DN15 – DN100 S DVOJČINNÝM PNEUMATICKÝM POHONEM PRISMA
BALL VALVE KV-L6N / PN40 DN15 – DN100 WITH PRISMA DOUBLE-ACTING PNEUMATIC ACTUATOR

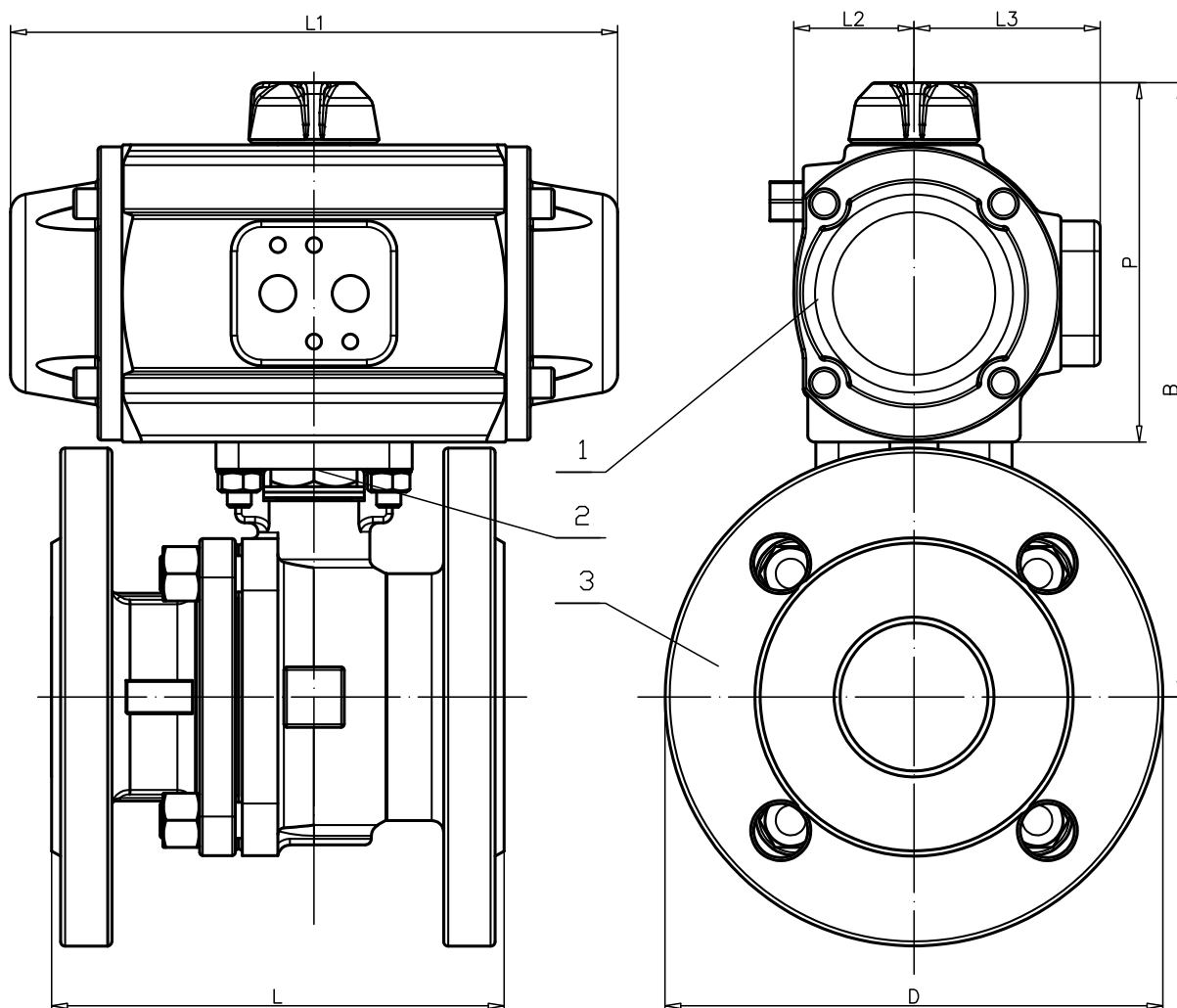

Pozice / Position	Název součásti / Name of component
1	Dvojčinný pneumatický pohon / Double-acting pneumatic actuator
2	Montážní sada / Mounting kit
3	Kulový kohout / Ball valve

Kohout kulový KV-L6N přírubový s dvojčinným pneumatickým pohonem Prisma
/ Ball valve KV-L6N, flanged type, with Prisma D/A pneumatic actuator

DN	PN	Pohon / Actuator	D	L	P	L1	L2	L3	B	Kg
15	40	PAW	95	115	89	141	28	48	137	3,6
20	40	PAW	105	120	89	141	28	48	142	4,4
25	40	PAW	115	125	89	141	28	48	148	5,2
32	40	PA00	140	130	102	155	32	52	173	7,4
40	40	PA05	150	140	119	201	40	62	195	10,1
50	40	PA05	165	150	119	201	40	62	204	12,8
65	40	PA10	185	170	123	226	41	63	230	17,5
80	40	PA15	200	180	139	265	48	71	256	25
100	40	PA25	235	190	175	358	64	89	315	40

**KULOVÝ KOHOUT KV-L6N / PN40 DN15 – DN100 S JEDNOČINNÝM PNEUMATICKÝM POHONEM PRISMA
BALL VALVE KV-L6N / PN40 DN15 – DN100 WITH PRISMA SINGLE-ACTING PNEUMATIC ACTUATOR**

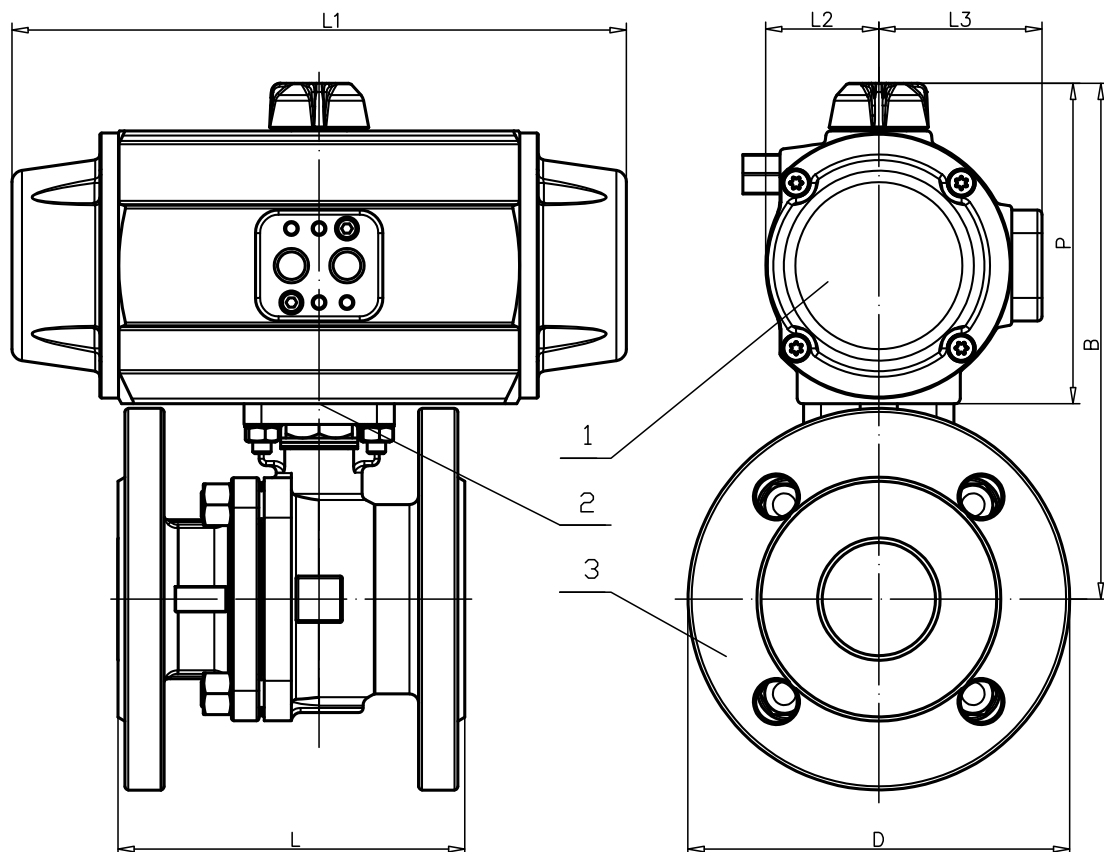

Pozice / Position	Název součásti / Name of component
1	Jednočinný pneumatický pohon / Single-acting pneumatic actuator
2	Montážní sada / Mounting kit
3	Kulový kohout / Ball valve

Kohout kulový přírubový KV-L6N s jednočinným pneumatickým pohonem Prisma / Ball valve, flanged type KV-L6N with Prisma S/A pneumatic actuator										
DN	PN	Pohon / Actuator	D	L	P	L1	L2	L3	B	Kg
15	40	PAWS	95	115	89	141	28	48	137	3,7
20	40	PA00S	105	120	102	155	32	52	155	5,1
25	40	PA05S	115	125	119	201	40	62	178	7,3
32	40	PA10S	140	130	119	201	40	62	190	9,4
40	40	PA15S	150	140	139	265	48	71	215	12,6
50	40	PA15S	165	150	139	265	48	71	224	15,3
65	40	PA25S	185	170	175	358	64	89	282	26,8
80	40	PA30S	200	180	191	429	72	97	308	37
100	40	PA30S	235	190	191	429	72	97	331	46

KULOVÝ KOHOUT KV-L6K / PN16 DN65 – DN200 S DVOJČINNÝM PNEUMATICKÝM POHONEM PRISMA
BALL VALVE KV-L6K / PN16 DN65 – DN200 WITH PRISMA DOUBLE-ACTING PNEUMATIC ACTUATOR

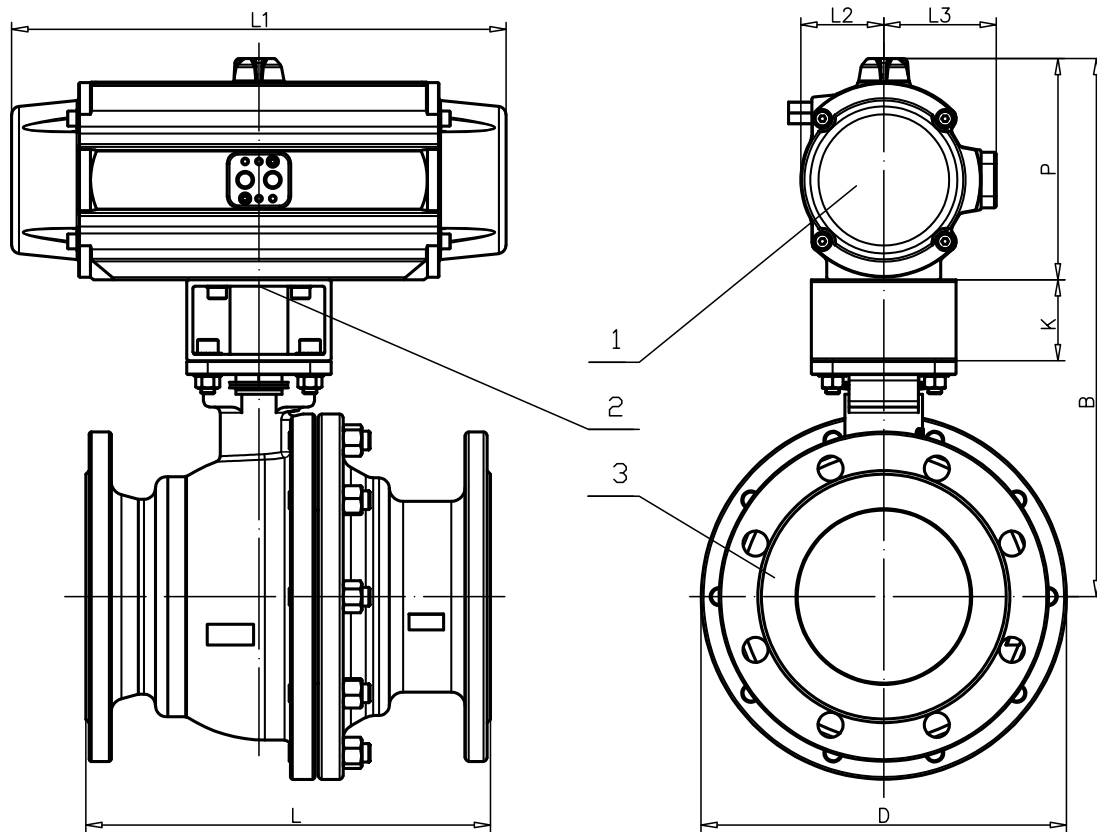

Pozice / Position	Název součásti / Name of component
1	Dvojčinný pneumatický pohon / Double-acting pneumatic actuator
2	Montážní sada / Mounting kit
3	Kulový kohout / Ball valve

Kohout kulový přírubový KV-L6K s dvojčinným pneumatickým pohonem Prisma / Ball valve, flanged type KV-L6K with Prisma D/A pneumatic actuator											
DN	PN	Pohon / Actuator	D	L	K	P	L1	L2	L3	B	Kg
65	16	PA10	185	170	-	123	226	41	63	225	17,3
80	16	PA15	200	180	-	139	265	48	71	251	23,9
100	16	PA25	235	190	-	175	358	64	89	315	37
125	16	PA30	250	325	70	191	429	72	97	444	65
150	16	PA30	285	350	70	191	429	72	97	465	89
200	16	P40	340	400	-	272	444	106	120	525	141

KULOVÝ KOHOUT KV-L6K / PN16 DN65 – DN200 S JEDNOČINNÝM PNEUMATICKÝM POHONEM PRISMA
BALL VALVE KV-L6K / PN16 DN65 – DN200 WITH PRISMA SINGLE-ACTING PNEUMATIC ACTUATOR

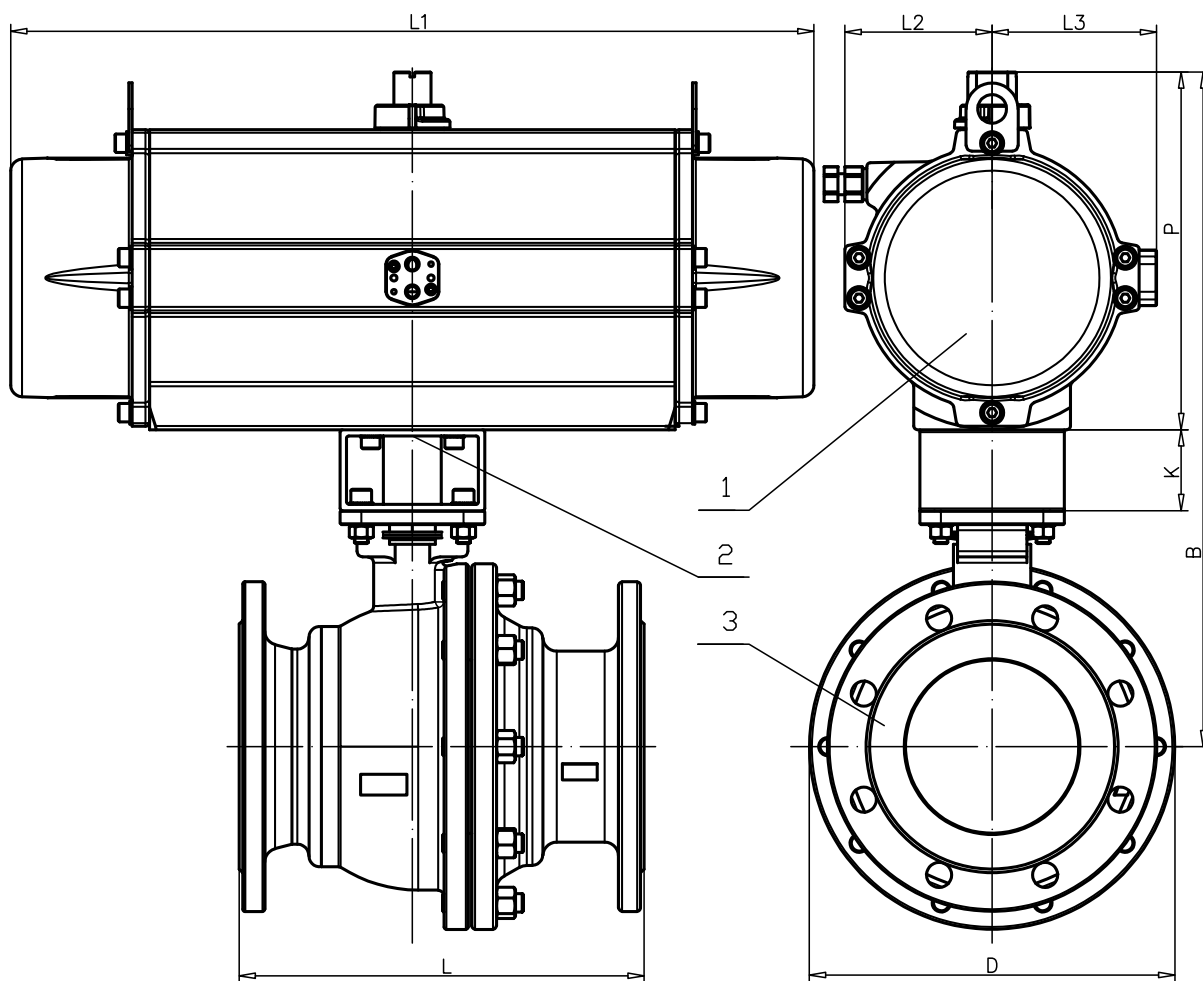

Pozice / Position	Název součásti / Name of component
1	Jednočinný pneumatický pohon / Single-acting pneumatic actuator
2	Montážní sada / Mounting kit
3	Kulový kohout / Ball valve

Kohout kulový přírubový KV-L6K s jednočinným pneumatickým pohonem Prisma / Ball valve, flanged type KV-L6K with Prisma S/A pneumatic actuator											
DN	PN	Pohon / Actuator	D	L	K	P	L1	L2	L3	B	Kg
65	16	PA25S	185	170	-	175	358	64	89	277	26
80	16	PA25S	200	180	-	175	358	64	89	287	30,6
100	16	PA30S	235	190	-	191	429	72	97	331	42
125	16	P40S	250	325	-	272	598	106	120	455	89
150	16	PA50S	285	350	70	309	694	128	141	583	136
200	16	PA50S	340	400	70	309	694	128	141	632	184

Certifikáty / Certificates

ISO 9001

ISO 14001

OHSAS 18001

PED 2014/68/EU

AD2000-W0

AD2000-HP0

AD2000- A4

DNV

SIL 3

TA-Luft

ISO 15848-1

ATEX 94/9/EC

EN 14432

API 6D

API607 / ISO10497

CRN

CU-TR

CCS

TS

Lloyd's Register

Bureau Veritas

