



- cast straight body
- welded seat
- disc made from stainless steel
- rising stem with outside screw and yoke
- asbestos-free packing

#### APPLICATION

- water or steam distribution
- cooling rooms
- petrochemical or chemical industry

#### ADVANTAGES

- compliance with emission standards
- easy installation and maintenance
- long service life



#### TECNICAL DATA

Working range:	water, steam, natural gas, oil, petroleum derivates and another non-aggressive working fluids; temperature range: -29 °C to +400 °C
The allowable pressure/temperature rating:	EN 12516-1
Construction materials:	carbon steel (please see more in table of Material of main parts)
Face to face:	EN 558-1, serie 1
Pipe connection:	butt weld ends acc. to EN 12627

Straight globe valves have a flow direction of the working fluid equal to the direction of the arrow on the body and are designed to operate in the OPEN or CLOSED position. They are not suitable for flow control in the basic version.

Operating:	hand wheel
Options:	hand wheel with lock hand wheel with limit switches operating by electric actuator other types of coatings according to customer requirements
Testing:	each globe valve is tested according to EN 12266 and supplied with accompanying documentation according to EN 10204
Certification:	PED 2014/68/EU

Picture 1

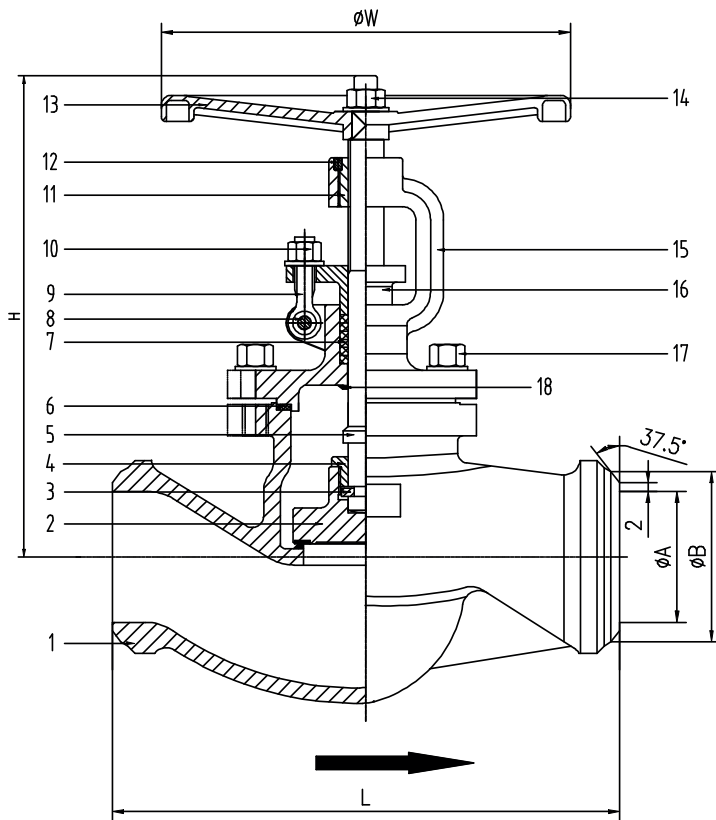

Table 1 Materials of main parts

Position	Description	Material
1	Body <sup>1)</sup>	GP240GH+13Cr (308L)
2	Disc	ASTM A276 AISI304
3	Sealing ring	Carbon steel
4	Sealing nut	Carbon steel
5	Stem	2Cr13
6	Seal	Graphit + AISI304
7	Packing	Graphit
8	Pin	Carbon steel
9	Eye bolt	ASTM A193 B7
10	Nut	ASTM A194 2H
11	Stem nut	ZCuAl10Fe3
12	Pin	Carbon steel
13	Hand wheel	Carbon steel
14	Nut	Carbon steel
15	Bonnet <sup>1)</sup>	GP240GH
16	Packing gland <sup>1)</sup>	GP240GH
17	Screw	ASTM A193 B7
18	Backseat	13Cr

<sup>1)</sup> with epoxy paint 100 -150 µm, RAL 5002

#### DIMENSIONS (mm)

DN	PN	L	øA	øB	H	øW	kg
15	40	130	16,1	22	190	140	3,50
20	40	150	22,3	28	190	140	4,00
25	40	160	28,5	35	195	160	5,00
32	40	180	35	42	210	180	7,50
40	40	200	43,1	50	220	180	10,00
50	40	230	54,5	62	230	200	12,00
65	40	290	68,9	77	280	200	19,00

*The data in this datasheet are informative only and the manufacturer reserves the right to changes of technical details.*