



- design BS 5351
- full bore
- split body, floating ball, PTFE seats
- ISO 5211 top flange
- antistatic device
- fire safe BS 6755, API 6FA, API 607

APPLICATION

- piping systems for processing, treatment and transport of liquid and gaseous media

ADVANTAGES

- low weight
- low pressure loss
- space saving construction
- easy installation and maintenance
- reliability
- possibility of automatic operation

TECHNICAL DATA

Working fluid: non-aggressive liquids and gases (water, steam, oil, air, fuel gases, oil and oil derivatives) depending on construction materials of valve

Working temperature: from -10 °C to +180 °C

Max. working pressure: 1,6 MPa, more in Pressure/Temperature Diagram

Construction materials: more in table of Materials of main construction parts

Face to face: acc. to manufacturer

Mounting between flanges acc. to EN 1092-1, B1 / PN 16

The ball valve is a two-way shut-off valve intended for installation in horizontal or vertical piping. The shut-off element is a ball with a through hole, which rotates through 90° and closes the working fluid flow in the seats. The ball valve is not suitable for abrasive working media and coagulating liquids. It is designed to operate either in the OPEN or CLOSED position.

Operating: hand wheel

Option: from DN 150 gearbox with hand wheel on request
 elektric or pneumatic operating
 degreasing service
 delivery including counter-flanges, sealing and bolting material

Testing: each ball valve shall be tested in accordance with EN 12266 and supplied with accompanying documentation according to EN 10204

Certification: PED 2014/68/ EU
ATEX 94/9/ CE

DESIGN AND CONSTRUCTION MATERIALS

Fig. 1 DN100 JADE type

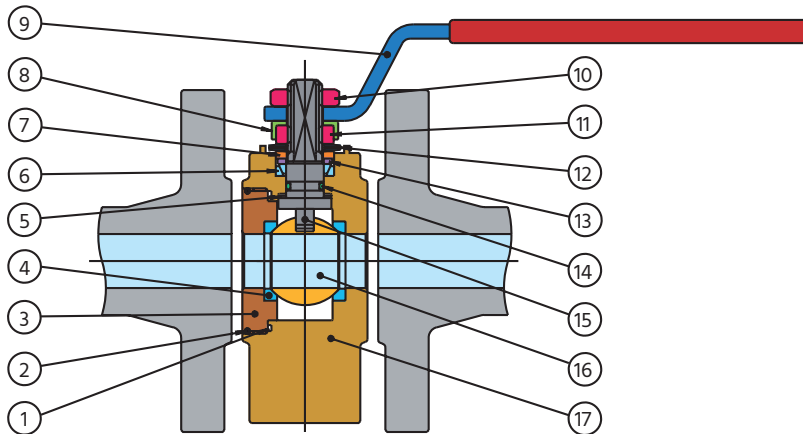

Table 1 Materials of main construction parts

Pos.	Description	Material
1	Gasket	PTFE
2	O-ring	NBR
3	2. part of body	ASTM A 105
4	Seats	PTFE
5	Washer	PTFE
6	Packing	PTFE
7	Operation - stop	AISI 304 (DIN 1.4301)
8	Fixing nut	AISI 304 (DIN 1.4301)
9	Hand lever	Fe P02 zinc.
10	Locking nut	steel galvanized
11	Retaining ring	steel galvanized
12	Spring washer	50 Cr V4
13	Thrust washers	AISI 304 (DIN 1.4301)
14	O-ring	FKM
15	Stem	AISI 304 (DIN 1.4301)
16	Ball	DN 15/40 AISI 316 (DIN 1.4401) DN 50/100 AISI 304 (DIN 1.4301)
17	1. part of body	ASTM A 105

Fig. 2 DN125–DN200 DIAMOND type

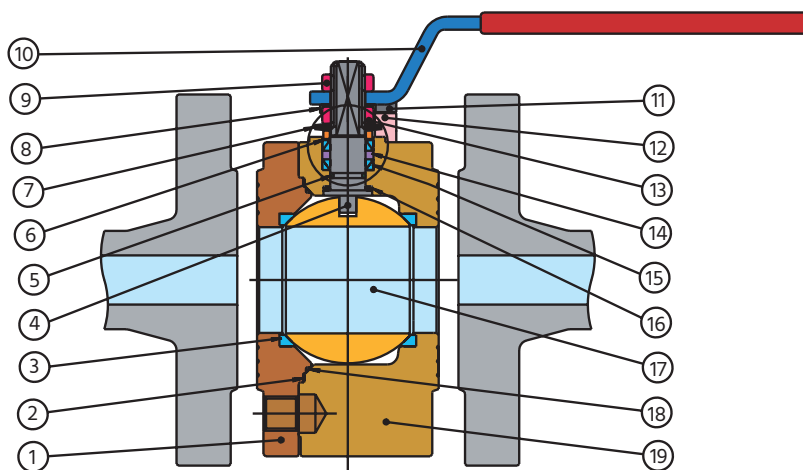
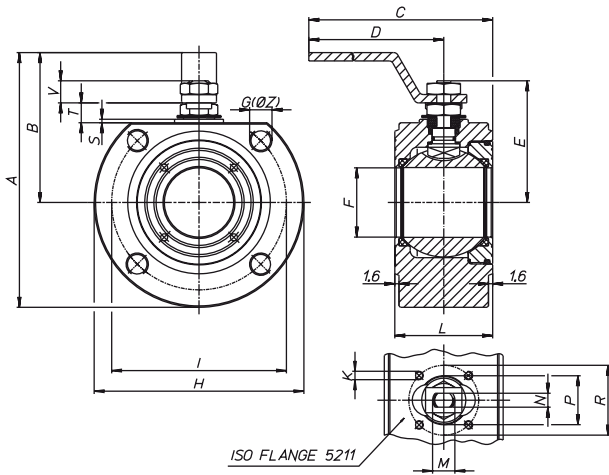

Table 2 Materials of main construction parts

Pos.	Description	Material
1	2. part of body	ASTM A 105
2	Gasket	Graft
3	Seats	PTFE
4	Stem	AISI 304 (DIN 1.4301)
5	O-ring	FKM
6	Washers	AISI 304 (DIN 1.4301)
7	Spring washer	50 Cr V4
8	Fixing nut	AISI 304 (DIN 1.4301)
9	Locking nut	ASTM A 105
10	Hand lever	ASTM A 105
11	Screw	ASTM A 105
12	Operation - stop	ASTM A 105
13	Retaining ring	ASTM A 105
14	Upper ring	PTFE
15	Packing	PTFE
16	Washer	PTFE
17	Ball	AISI 304 (DIN 1.4301)
18	Gasket	PTFE
19	1. part of body	ASTM A 105

TECHNICAL DRAWING AND DIMENSIONS

Fig. 3 DN100 JADE type



DN125-DN200 DIAMOND type

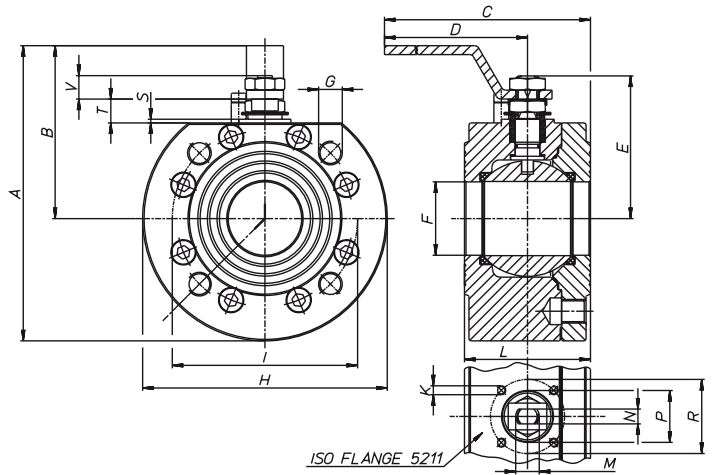
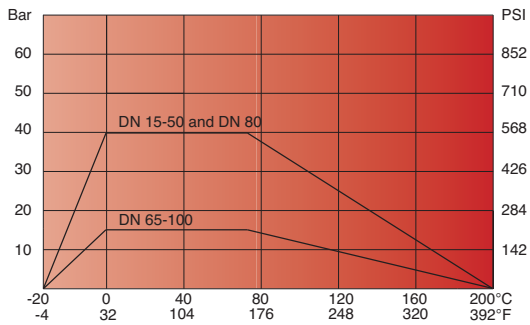

Table 3

K85 171 516 / PN16	Dimensions (mm)																			Num. of wholes	ISO 5211	kg		
JADE	A	B	C	D	E	F	G	H	K	I	L	M	N	P	R	S	T	V						
DN 100	275	165	440	370	148,5	96	M16	220	M10	180	140	M27	16	70	102	3	22,2	25,3	8	F10	31,5			
DIAMOND																								
DN 125	309	181	455	370	166,5	118	M16	255	M10	210	185	M27	16	70	102	3	22,2	25,3	8	F10	54,2			
DN 150	396	249	689	584	200	144	M20	295	M12	240	235	M42	26	...	125	...	4	31,5	8	F12	90,5			
DN 200	475	288	739	584	235	192	M20	373	M12	295	310	M42	26	...	125	...	4	27	12	F12	177			

PRESSURE/TEMPERATURE DIAGRAM - JADE



HEAD LOSS DIAGRAM - JADE

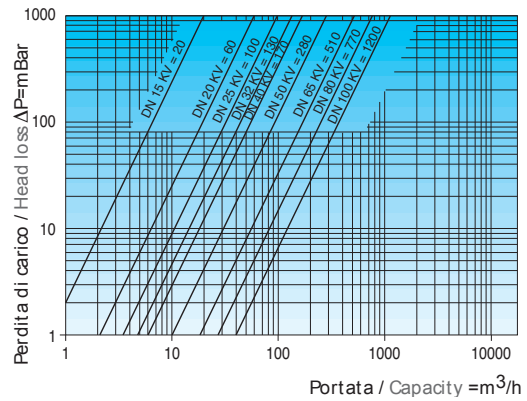

PRESSURE/TEMPERATURE DIAGRAM - DIAMOND

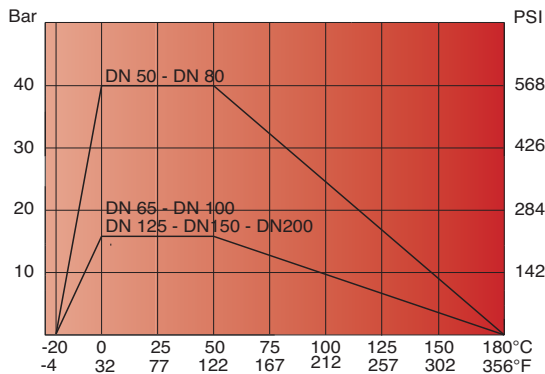

HEAD LOSS DIAGRAM - DIAMOND

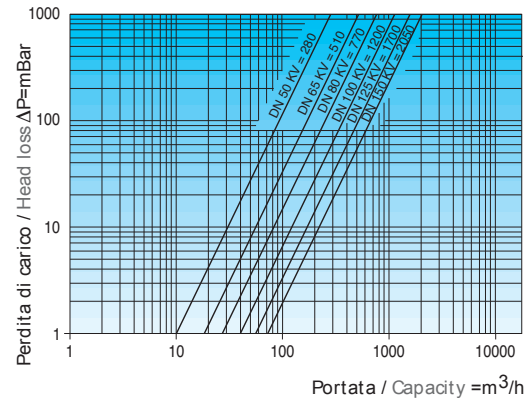

BREAKING TORQUES - JADE/DIAMOND

DN	100	125	150	200
PN (bar)	Kroučící moment (Nm)			
0	150	240	310	600
16	168	300	400	800

Note:

For safe operation of valves with pneumatic or electric control, the relevant safety factor must be taken into account when dimensioning the actuator.

TECHNICAL DRAWING AND DIMENSIONS OF BALL VALVE PN16 JADE DN100 WITH DOUBLE-ACTING PNEUMATIC ACTUATOR

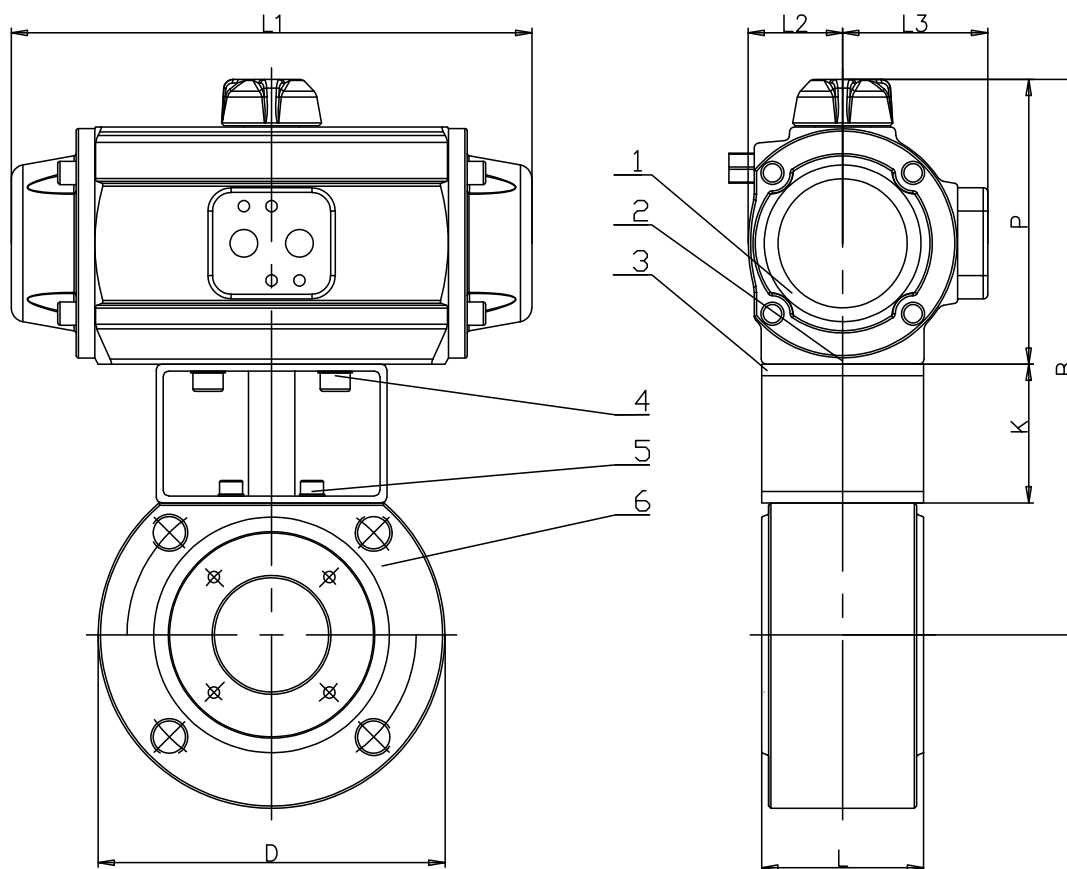

1	Dvojitý pneumatický pohon / Double acting pneumatic actuator										
2	Vložka / Connection										
3	Montážní sada / Mounting Kit										
4	Šrouby / Bolts A										
5	Šrouby / Bolts B										
6	Kulový kohout / Ball valve JADE										
Kohout kulový mezipřírubový s dvojitým pneumatickým pohonem JADE											
Wafer ball valve with doubleacting pneumatic actuator JADE											
DN	PN	Pohon / Actuator	D	L	K	P	L1	L2	L3	B	Kg
100	16	PA25	220	140	80	175	358	64	89	356	44

TECHNICAL DRAWING AND DIMENSIONS OF BALL VALVE PN16 JADE DN100 WITH SINGLE-ACTING PNEUMATIC ACTUATOR

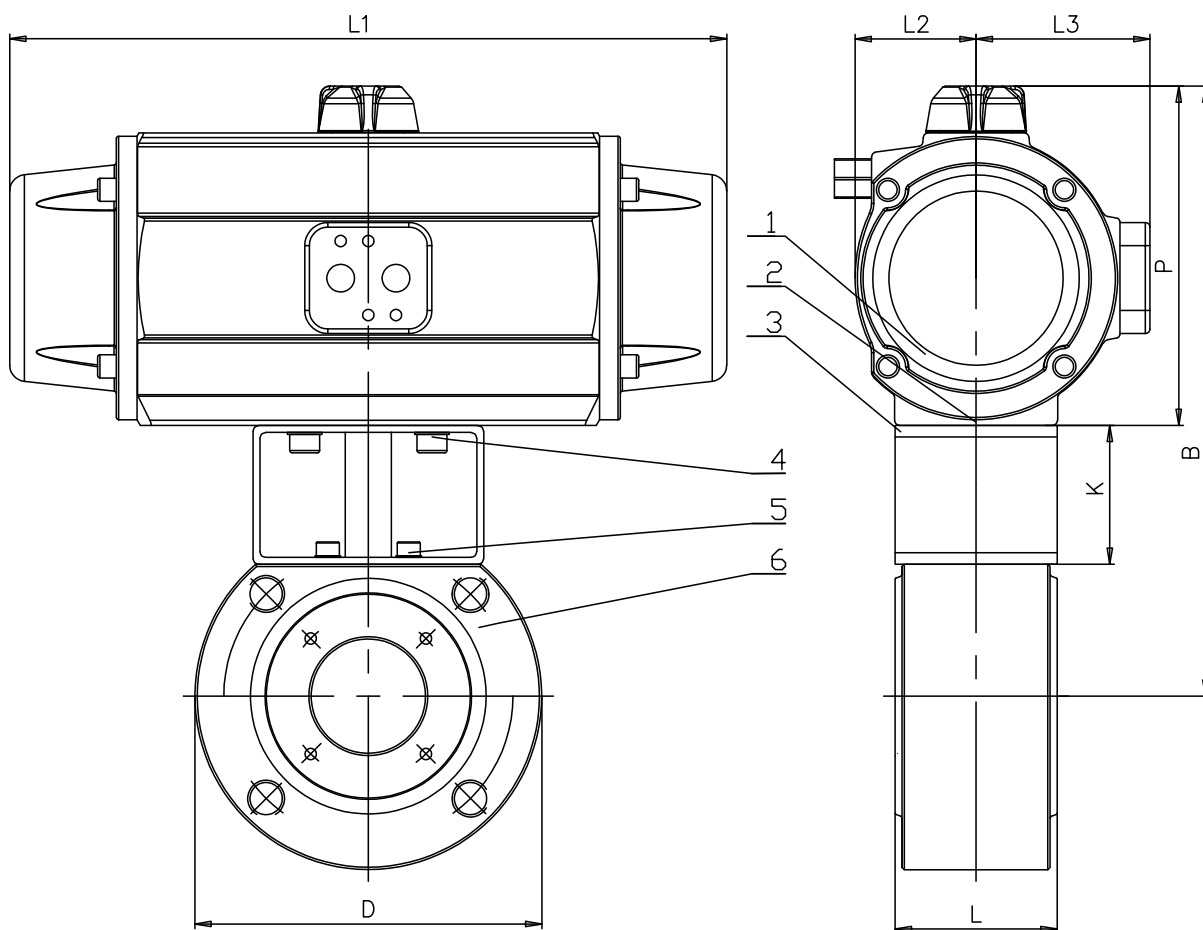

1	Jednočinný pneumatický pohon / Single acting pneumatic actuator											
2	Vložka / Connection											
3	Montážní sada / Mounting Kit											
4	Šrouby / Bolts A											
5	Šrouby / Bolts B											
6	Kulový kohout / Ball valve JADE											
Kohout kulový mezipřírubový s jednočinným pneumatickým pohonem JADE												
Wafer ball valve with single acting pneumatic actuator JADE												
DN	PN	Pohon / Actuator	D	L	K	P	L1	L2	L3	B	Kg	
100	16	P40S	220	140	80	272	598	106	120	453	71	

TECHNICAL DRAWING AND DIMENSIONS OF BALL VALVE PN16 DIAMOND DN125÷200 WITH DOUBLE-ACTING PNEUMATIC ACTUATOR

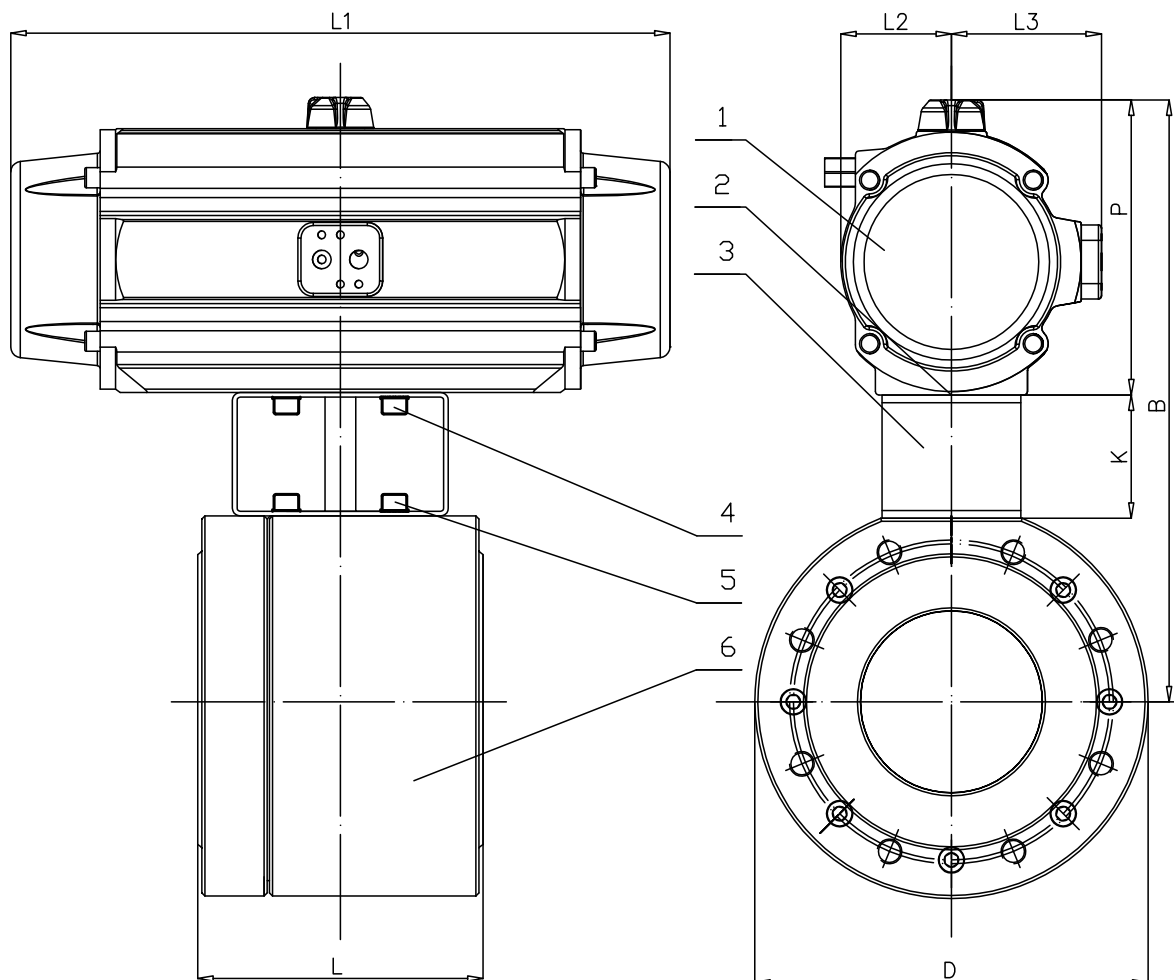

1	Dvojičný pneumatický pohon / Double acting pneumatic actuator										
2	Vložka / Connection										
3	Montážní sada / Mounting Kit										
4	Šrouby / Bolts A										
5	Šrouby / Bolts B										
6	Kulový kohout / Ball valve DIAMOND										
Kohout kulový mezipřírubový s dvojičným pneumatickým pohonem DIAMOND PN16											
Wafer ball valve with doubleacting pneumatic actuator DIAMOND PN16											
DN	PN40	Pohon / Actuator	D	L	K	P	L1	L2	L3	B	Kg
125	16	PA30	255	185	80	191	429	72	97	390	69
150	16	P40	295	235	80	272	444	106	120	517	114
200	16	P40	373	310	80	272	444	106	120	556	202

TECHNICAL DRAWING AND DIMENSIONS OF BALL VALVE PN16 DIAMOND DN125÷200 WITH SINGLE-ACTING PNEUMATIC ACTUATOR

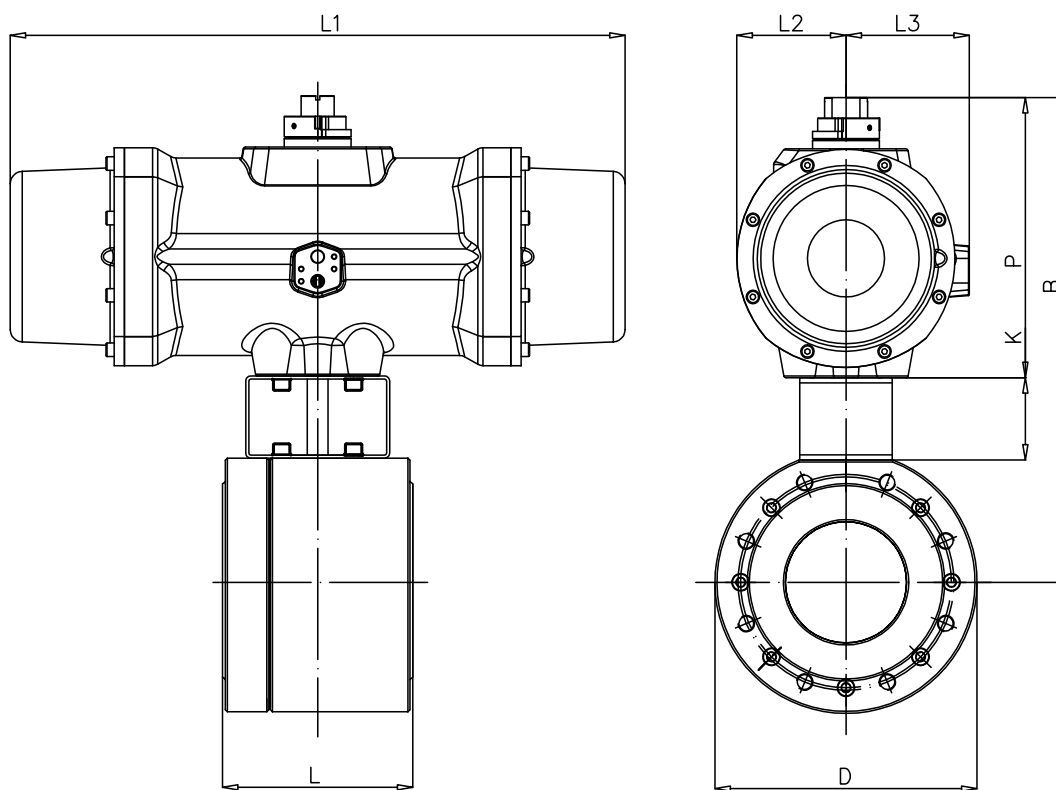

1	Jednočinný pneumatický pohon / Single acting pneumatic actuator										
2	Vložka / Connection										
3	Montážní sada / Mounting Kit										
4	Šrouby / Bolts A										
5	Šrouby / Bolts B										
6	Kulový kohout / Ball valve DIAMOND										
Kohout kulový mezipřírubový s jednočinným pneumatickým pohonem DIAMOND PN16											
Wafer ball valve with single acting pneumatic actuator DIAMOND PN16											
DN	PN40	Pohon / Actuator	D	L	K	P	L1	L2	L3	B	Kg
125	16	P40S	255	185	80	272	598	106	120	471	94
150	16	PA50S	295	235	90	309	694	128	141	564	159
200	16	PA60S	373	310	120	368	672	160	185	692	266

The data given in the catalog are informative and the manufacturer reserves the right to make technical changes.