



- Forged or casted body and bonnet
- Pressure seal design
- Rising stem (RS), outside screw and yoke (OS&Y)
- Dimensions over DN 50 with balancing disc
- Seats are welded on

APPLICATIONS

- Power plant
- Chemical
- Petrochemical
- Refining and other



ADVANTAGES

- Long service life
- Respect to emission standards
- Easy handling and maintenance

TECHNICAL DATA

Media:	Depending on the valve materials: water, steam, gas, oil and oil derivates and other non aggressive media
Pressure and temperature:	Pressure up to 500 bar Class 1 500 up to Class 2500 Temperature up to 600 °C
Materials:	Carbon and heat resistant alloy steels
Options:	Electric, hydraulic or pneumatic actuator Y-Type (VHPY) Angle type (VHPA) Position indicator Extended stem Spring loaded stuffing box (SLSB) Locking device Tandem Valves Flanges and welding ends according to: EN, ASME, GOST, DIN, etc. Other paint finishes are available upon customer's request Valve complete with counter flanges, bolting and gaskets
Testing:	Every produced valve was tested according to EN 12266 or API 598

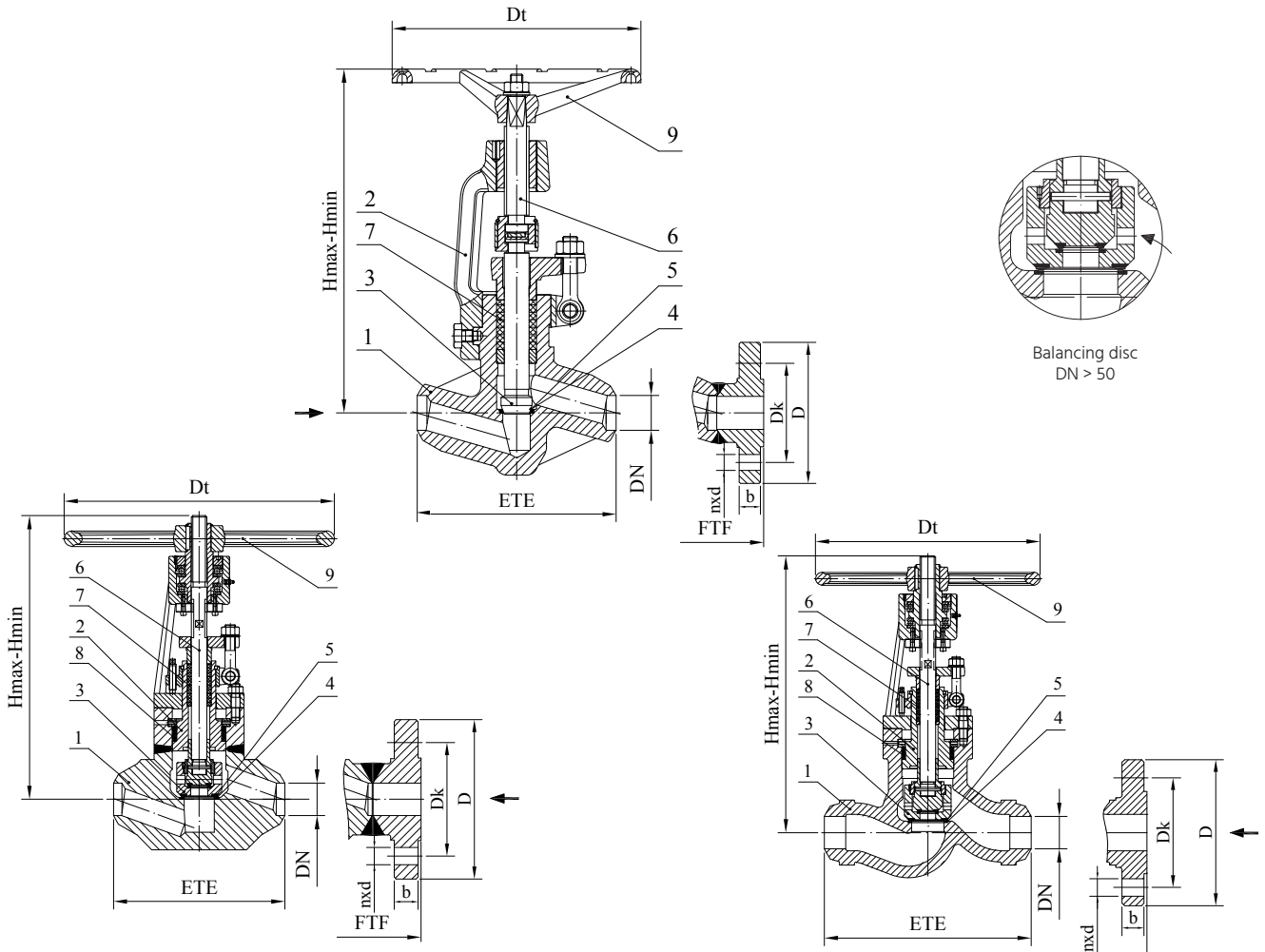

LIST OF MATERIALS

Item	Part	Material Group acc. to EN 12516-1 and ASME B16.34				
		3E0 (1.1)	4E0 (1.5 a 1.3)	5E0 (1.9)	6E0 (1.10)	9E1 / 1C15 (1.15)
		Application				
		up to 400 °C (-29 °C ÷ 425 °C)	up to 550 °C (-29 °C ÷ 470 °C)	up to 550 °C (-29 °C ÷ 595 °C)	up to 600 °C (-29 °C ÷ 595 °C)	up to 600 °C (-29 °C ÷ 600 °C)
1	Body ¹⁾	1.0460 / 1.0619 (A105 / WCB)	1.5415 / 1.5419 (F1 / WC1)	1.7335 / 1.7357 (F11 Cl.2 / WC6)	1.7383 / 1.7379 (F11 Cl.3 / WC9)	1.4903 / C12A (F91 / C12A)
2	Bonnet ¹⁾	1.0460 / 1.0619 (A105 / WCB)	1.5415 / 1.5419 (F1 / WC1)	1.7335 / 1.7357 (F11 Cl.2 / WC6)	1.7383 / 1.7379 (F11 Cl.3 / WC9)	1.4903 (F91 / C12A)
3	Disc ¹⁾	1.4021 / 1.4122				
4	Body welded on with	13 Cr (up to 450 °C) or Stellite				
5	Disc welded on with	13 Cr (up to 450 °C) or Stellite				
6	Stem	1.4021				
7	Stem Packing	graphite with corrosion inhibitor				
8	Body/Bonnet gasket	graphite with corrosion inhibitor				
9	Handwheel	cast iron or epoxy coated steel				

¹⁾ other materials available according to EN and ASTM standards

STANDARDS:

High Pressure Globe Valves	Class 1500 ÷ Class 2500 and PN 250 ÷ PN 630
Face-to face dimensions according to	ASME B16.10 and Manufacturer standard
Flanged ends according to	ASME B16.5 or EN 1092-1
Welding ends according to	ASME B16.25 or EN 12627

VHP PN 250 - DIMENSIONS

DN		10	15	20	25	32	40	50	65	80	100	125	150	200
[mm]	ETE	110	160	160	160	210	260	300	350	400	450	600	600	750
	FTF	230	230	(2)	260	(2)	300	350	400	450	520	600	700	800
	D	125	130	-	150	-	185	200	230	255	300	340	390	485
	Dk	85	90	-	105	-	135	150	180	200	235	275	320	400
	nxd	4×18	4×18	-	4×22	-	4×26	8×26	8×26	8×30	8×33	12×33	12×33	12×42
	b	24	26	-	28	-	34	38	42	46	54	60	68	82
	Hmax	191	231	259	307	371	376	438	585	694	822	1 228 (4)	1 228 (4)	1 780 (4)
	Hmin	182	220	241	284	346	351	411	555	662	777	1 148 (4)	1 148 (4)	1 696 (4)
	Dt	100	150	150	200	300	300	400	500	630	630	500 (3)	500 (3)	630 (3)
kg	ETE	1,5	5	5	8,5	19	24	39	70	140	210	655	655	932
	FTF	5,5	10	(2)	15	(2)	37	55	96	173	264	733	774	1 152

VHP PN 320 - DIMENSIONS

DN		10	15	20	25	32	40	50	65	80	100	125	150	200
[mm]	ETE	110	160	160	160	210	260	300	350	400	450	600	600	750
	FTF	230	230	(2)	260	(2)	300	350	400	450	520	600	700	800
	D	125	130	-	160	-	195	210	255	275	335	380	425	525
	Dk	85	90	-	115	-	145	160	200	220	265	310	350	440
	nxd	4×18	4×18	-	4×22	-	4×26	8×26	8×30	8×30	8×36	12×36	12×39	16×42
	b	24	26	-	34	-	38	42	51	55	65	75	84	103
	Hmax	191	231	259	307	371	376	438	585	694	822	1 228 (4)	1 228 (4)	1 780 (4)
	Hmin	182	220	241	284	346	351	411	555	662	777	1 148 (4)	1 148 (4)	1 696 (4)
	Dt	100	150	150	200	300	300	400	500	630	630	500 (3)	500 (3)	630 (3)
kg	ETE	1,5	5	5	8,5	20	24	39	70	140	210	655	655	932
	FTF	5,5	10	(2)	18	(2)	41	60	109	190	295	782	838	1 276

VHP PN 400 - DIMENSIONS

DN		10	15	20	25	32	40	50	65	80	100	125	150	200
[mm]	ETE	110	160	160	160	210	260	300	350	400	450	600	600	750
	FTF	230	230	(2)	260	(2)	300	350	400	450	520	600	700	800
	D	125	145	-	180	-	220	235	290	305	370	415	475	585
	Dk	85	100	-	130	-	165	180	225	240	295	340	390	490
	nxd	4×18	4×22	-	4×26	-	4×30	8×30	8×33	8×33	8×39	12×39	12×42	16×48
	b	28	30	-	38	-	48	52	64	68	80	92	105	130
	Hmax	191	231	259	307	371	376	438	585	694	822	1 228 (4)	1 228 (4)	1 780 (4)
	Hmin	182	220	241	284	346	351	411	555	662	777	1 148 (4)	1 148 (4)	1 696 (4)
	Dt	100	150	150	200	300	300	400	500	630	630	500 (3)	500 (3)	630 (3)
kg	ETE	1,5	5	5	8,5	20	24	39	70	140	210	655	655	932
	FTF	6,5	12	(2)	23	(2)	52	72	133	216	345	844	945	1 472

VHP PN 500 - DIMENSIONS

DN		10	15	20	25	32	40	50	65	80	100
[mm]	ETE	110	160	160	160	260	260	300	350	400	450
	Hmax	191	259	307	307	376	376	438	585	694	822
	Hmin	192	241	284	284	351	351	411	555	662	777
	Dt	100	150	200	200	300	300	400	500	630	630
kg	ETE	1,5	5	8,5	8,5	24	24	39	70	140	210

VHP Class 1 500 - DIMENSIONS

DN		15	20	25	32	40	50	65	80	100	125	150	200
[mm]	ETE	160	160	160	210	210	216	254	305	406	483	559	711
	FTF	216	229	254	279	305	368	419	470	546	673	705	832
	D	120	130	149	160	180	215	245	265	310	375	395	485
	Dk	82,6	88,9	101,6	111,1	123,8	165,1	190,5	103,2	241,3	292,1	317,5	393,7
	nxd	4×22,2	4×22,2	4×25,4	4×25,4	4×28,6	8×25,4	8×28,6	8×31,7	8×34,9	8×41,3	12×38,1	12×44,5
	b	29,3	32,4	35	35,6	38,8	45,1	48,3	54,7	61,0	80,1	89,6	99,1
	Hmax	259	259	307	371	371	390	450	694	822	1 228 (4)	1 228 (4)	1 780 (4)
	Hmin	241	241	284	346	346	360	415	662	777	1 148 (4)	1 148 (4)	1 696 (4)
Dt	150	150	200	300	300	400	500	630	630	500 (3)	500 (3)	630 (3)	
kg	ETE	5	5	8,5	19	19	21	57	80	170	260	375	670
	FTF	9	11	15,5	28	30	39	84	113	211	325	460	810

RANGE OF APPLICATION

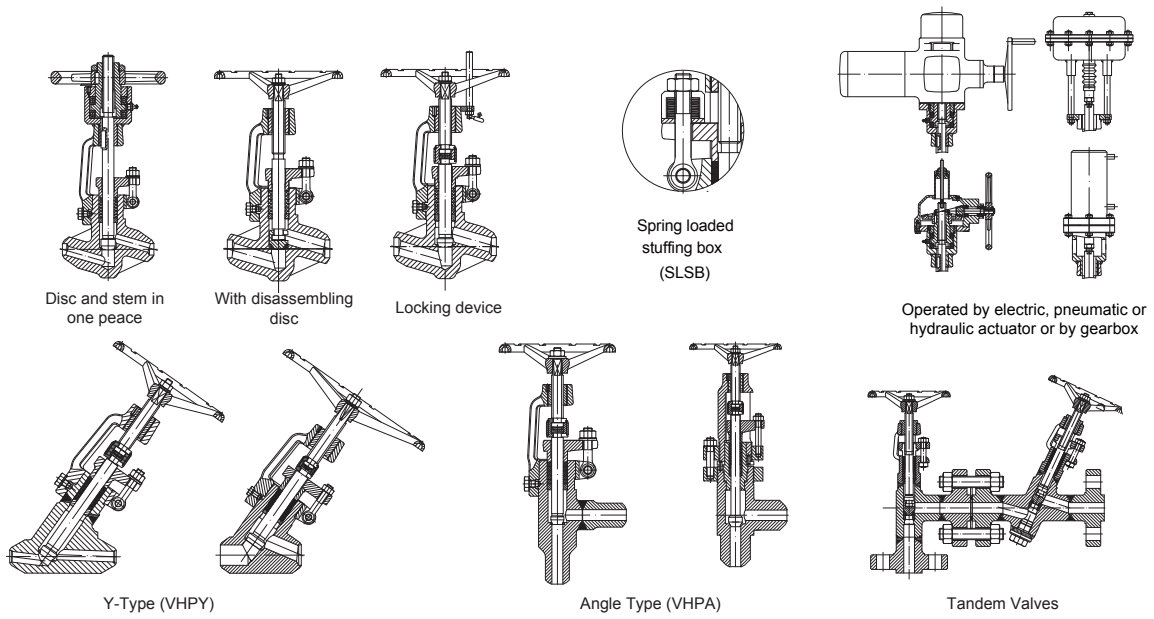

The data in this datasheet are informative only and the manufacturer reserves the right to changes of technical details.

